

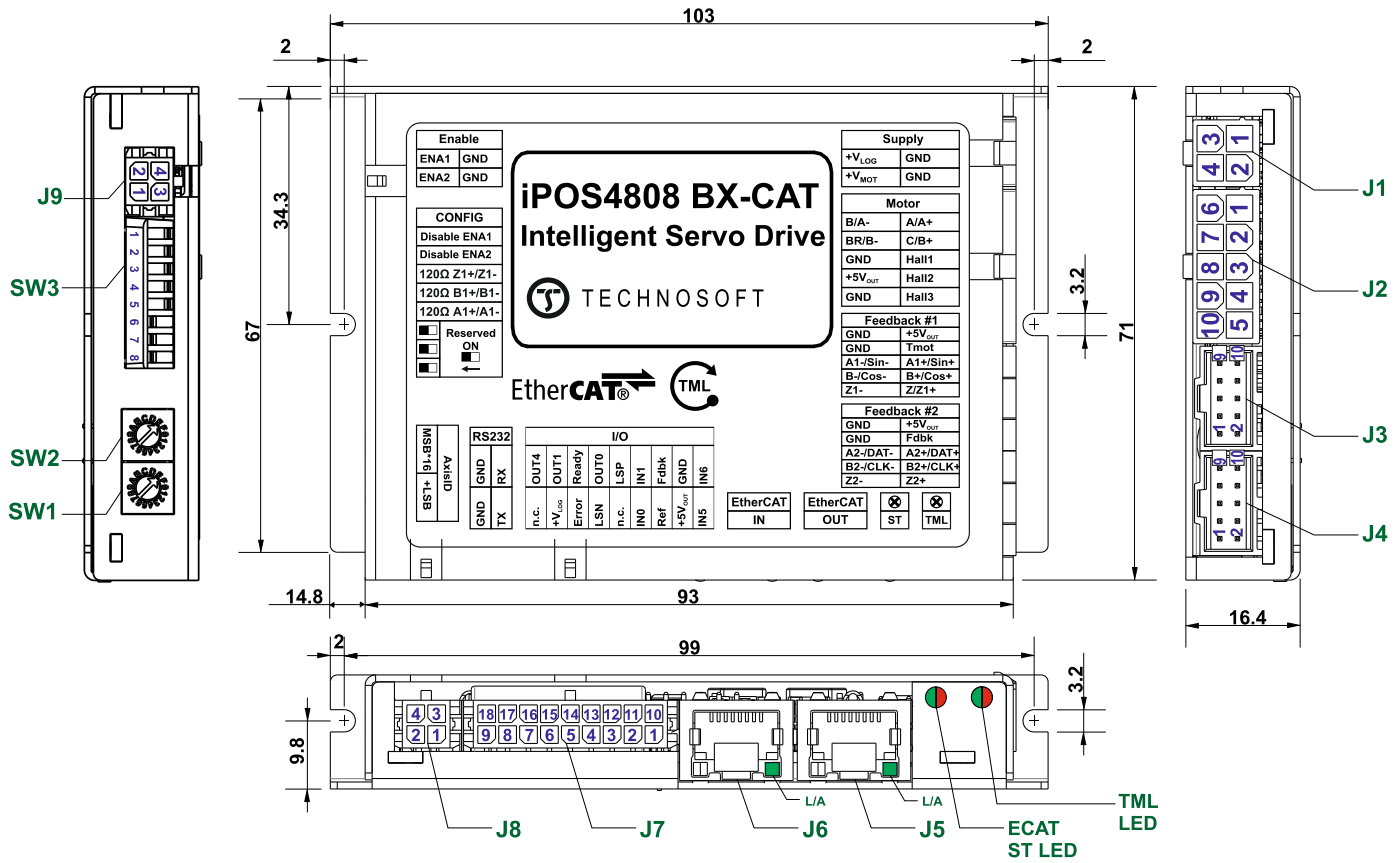

iPOS4808 BX-CAT DATASHEET

P/N: P027.214.E221



Motor – sensor configurations						
Sensor	Motor					
	PMSM	BLDC	DC BRUSH	STEP (2-ph)	STEP ² (3-ph)	
Incr. Encoder	☑		☑	☑	☑	
Incr. Encoder + Hall	☑	☑				
Analog Sin/Cos	☑	☑	☑	☑	☑	
SSI	☑	☑	☑	☑	☑	
BiSS-C	☑	☑	☑	☑	☑	
EnDAT ¹	☑	☑	☑	☑	☑	
Linear Halls ³	☑					
Tacho			☑			
Open-loop (no sensor)				☑	☑	

¹ Available starting with F515K firmware version

² Sensor used only for step loss detection

³ For more details, please contact Technosoft

- **Features**
- Motor supply: 11-50V. Logic supply: 9-36V
- Output current: 8A cont. (BLDC mode); 20A_{PEAK}, up to 100KHz PWM
- Feedback Devices (dual-loop support)
- 1st feedback devices supported:
 - Incremental encoder interface (single ended or differential)
 - pulse & direction interface (single ended) for external (master) digital reference
 - Analogue sin/cos encoder interface (differential 1V_{pp})
 - Digital Hall sensor interface (single-ended and open collector)
- 2nd feedback devices supported:
 - Incremental encoder interface (differential)
 - pulse & direction interface (differential) for external (master) digital reference
- SSI/BiSS-C/EnDAT¹ encoder interface
- Separate ENABLE circuit: connect both ENA1 and ENA2 inputs to +24V to allow motor PWM output operation
- 6 digital inputs, 12-36V, PNP/NPN programmable: 2 for limit switches, 4 general-purpose
- 5 digital outputs, 5-36V, 0.5A, NPN open-collector: Ready, Error, 3 general-purpose
- 2 analogue inputs: 12-bit, 0-5V: Reference, Feedback or general purpose
- RS-232 serial & dual 100Mbps RJ45 EtherCAT® interfaces
- EtherCAT® with CAN application protocol over EtherCAT (CoE)
- 127 h/w addresses selectable by h/w rotary hex switches
- 16k x 16 SRAM memory for data acquisition
- 16k x 16 E²ROM to store setup data, TML motion programs, cam tables and other user data
- Operating ambient temperature: 0-40°C (over 40°C with derating)
- NTC/PTC analogue Motor Temperature sensor input

Name EP	First edition January 12, 2018	Document template: P099.TQT.564.0001	Last edition May 28, 2024	Visa : AN
		Title of document iPOS4808 BX-CAT PRODUCT DATA SHEET	N° document P027.214.E221.DSH.10G	Page: 1 of 5



iPOS4808 BX-CAT DATASHEET

P/N: P027.214.E221

Mating Connectors				
Producer	Part No.	Connector	Description	Wire Gauge
MOLEX	39-03-9042	J1	MINIFIT JR. receptacle housing, 2x2 way	AWG 18-20
MOLEX	39-03-9102	J2	MINIFIT JR. receptacle housing, 2x5 way	AWG 18-20
MOLEX	45750-1111	J1, J2	CRIMP PIN, MINIFIT JR., 13A	AWG 18-20
MOLEX	90142-0010	J3, J4	C-Grid III™ Crimp Housing Dual Row, 10 Circuits, with retention	AWG 22..24
	90143-0010		C-Grid III™ Crimp Housing Dual Row, 10 Circuits, without retention	
MOLEX	90119-0109	J3, J4	C-Grid III™ Crimp Terminal	AWG 22..24
MOLEX	43025-1800	J7	MICROFIT RECEPTACLE HOUSING, 2x9 WAY	AWG 20..24
MOLEX	43025-0400	J8, J9	MICROFIT RECEPTACLE HOUSING, 2x2 WAY	AWG 20..24
MOLEX	43030-0007	J7, J8, J9	CRIMP PIN, MICROFIT, 5A	AWG 20..24
-	-	J5, J6	Standard 8P8C modular jack (RJ-45) male	-

Connectors Description

Pin	Name	Type	Description
J1	1	GND	- Negative return (ground) of the power supply
	2	GND	- Negative return (ground) of the power supply
	3	+V _{LOG}	I Positive terminal of the logic supply input: 9 to 36V _{DC}
	4	+V _{MOT}	I Positive terminal of the motor supply: 11 to 50V _{DC} .

Pin	Name	Type	Description
J2	1	A/A+	O Phase A for 3-ph motors, A+ for 2-ph steppers, Motor+ for DC brush motors
	2	C/B+	O Phase C for 3-ph motors, B+ for 2-ph steppers
	3	Hall 1	I Digital input Hall 1 sensor
	4	Hall 2	I Digital input Hall 2 sensor
	5	Hall 3	I Digital input Hall 3 sensor
	6	B/A-	O Phase B for 3-ph motors, A- for 2-ph steppers, Motor- for DC brush motors
	7	BR/B-	O Brake resistor / Phase B- for step motors
	8	GND	- Negative return (ground) of the motor supply
	9	+5V _{OUT}	O 5V output supply - internally generated
	10	GND	- Negative return (ground) of the motor supply

Pin	Name	Type	Description
J3	1	Z1-	I Incr. encoder1 Z- diff. input
	2	Z1+	I Incr. encoder1 Z single-ended, or Z+ diff. input
	3	B1-/Cos-	I Incr. encoder1 B- diff. input, or analogue encoder Cos- diff. input
	4	B1+/Cos+/Dir	I Incr. encoder1 B single-ended, or B+ diff. input, or Dir, or analogue encoder Cos+ diff. input
	5	A1-/Sin-	I Incr. encoder1 A- diff. input, or analogue encoder Sin- diff. input
	6	A1+/Sin+/Pulse	I Incr. encoder1 A single-ended, or A+ diff. input, or Pulse, or analogue encoder Sin+ diff. input
	7	GND	- Return ground for sensors supply
	8	Temp Mot	I NTC/PTC input. Used to read an analog temperature value
	9	GND	- Return ground for sensors supply
	10	+5V _{OUT}	O 5V output supply for I/O usage

Pin	Name	Type	Description	
1	Z2-	I	Incr. encoder2 Z- diff. input; has 120Ω resistor between pins 1 and 2	
2	Z2+	I	Incr. encoder2 Z+ diff. input; has 120Ω resistor between pins 1 and 2	
J4	3	B2-/Dir-/CLK-/MA-	I/O Incr. encoder2 B- diff. input, or Dir-, or Clock- for SSI & EnDAT, or Master- for BiSS; has 120Ω resistor between pins 3 and 4	
	4	B2+/Dir+/CLK+/MA+	I/O Incr. encoder2 B+ diff. input, or Dir+, or Clock+ for SSI & EnDAT, or Master+ for BiSS; has 120Ω resistor between pins 3 and 4	
	5	A2-/Pulse-/Data-/SL-	I Incr. encoder2 A- diff. input, or Pulse-, or Data- for SSI & EnDAT, or Slave- for BiSS; has 120Ω resistor between pins 5 and 6	
	6	A2+/Pulse+/Data+/SL+	I Incr. encoder2 A+ diff. input, or Pulse+, or Data+ for SSI & EnDAT, or Slave+ for BiSS; has 120Ω resistor between pins 5 and 6	
	7	GND	-	Return ground for sensors supply
	8	FDBK	I	Analogue input, 12-bit, 0-5V. Used to read an analogue position or speed feedback (as tacho), or used as general purpose analogue input; Also connected to J7 pin12.
9	GND	-	Return ground for sensors supply	
10	+5V _{OUT}	O	5V output supply for sensors usage	

Port	Name	Type	Description
J5	ECAT OUT	O	EtherCAT standard RJ45 Ethernet OUT port
J6	ECAT IN	I	EtherCAT standard RJ45 Ethernet IN port

Pin	Name	Type	Description
J7	1	IN5	I 12-36V general-purpose digital PNP/NPN input
	2	+5V _{OUT}	O 5V output supply for I/O usage
	3	REF	I Analogue input, 12-bit, 0-5V. Used to read an analog position, speed or torque reference, or used as general purpose analogue input
	4	IN0	I 12-36V general-purpose digital PNP/NPN input
	5	n.c.	- not connected
	6	IN3/LSN	I 12-36V digital PNP/NPN input. Negative limit switch input
	7	OUT2/ Error	O 5-36V 0.5A, drive Error output, active low, NPN open-collector/TTL pull-up. Also drives the red Error LED.
	8	+V _{LOG}	I Positive terminal of the logic supply: 9 to 36V _{DC}
	9	n.c.	- not connected
	10	IN6	I 12-36V general-purpose digital PNP/NPN input
	11	GND	- Return ground for I/O pins
	12	FDBK	I Analogue input, 12-bit, 0-5V. Used to read an analogue position or speed feedback (as tacho), or used as general purpose analogue input; Connected also to J4 pin 8.
	13	IN1	I 12-36V general-purpose digital PNP/NPN input
	14	IN2/LSP	I 12-36V digital PNP/NPN input. Positive limit switch input
	15	OUT0	O 5-36V 0.5A, general-purpose digital output, NPN open-collector/TTL pull-up
	16	OUT3/ Ready	O 5-36V 0.5A, drive Ready output, active low, NPN open-collector/TTL pull-up. Also drives the green Ready LED.
	17	OUT1	O 5-36V 0.5A, general-purpose digital output, NPN open-collector/TTL pull-up
	18	OUT4	O 5-36V 0.5A, general-purpose digital output, NPN open-collector/TTL pull-up

Name EP	First edition January 12, 2018	Document template: P099.TQT.564.0001	Last edition May 28, 2024	Visa : AN
		Title of document iPOS4808 BX-CAT PRODUCT DATA SHEET	N° document P027.214.E221.DSH.10G Page: 2 of 5	



iPOS4808 BX-CAT DATASHEET

P/N: P027.214.E221

Pin	Name	Type	Description
1	232TX	O	RS-232 Data Transmission
2	GND	-	Return ground for RS-232 pins
3	232RX	I	RS-232 Data Reception
4	GND	-	Return ground for RS-232 pins

Pin	Name	Type	Description
1	ENA2	I	Enable circuit input2; connect ENA1&ENA2 to 18÷40V to activate motor operation
2	ENA1	I	Enable circuit input1; connect ENA1&ENA2 to 18÷40V to activate motor operation
3	GND	-	Return ground
4	GND	-	Return ground

Switch	Position	Description
SW1	0..F	H/W Axis ID = SW2(MSB)*16 + SW1(LSB) Exception: SW2=0 and SW1 = 0 -->Axis ID = 255. Remark:SW2 should be set only between 0 and 7.
SW2	0..7	

Pin	Position	Description
1	down(ON)	Disable ENA1 functionality. Connects internally +V _{LOG} to ENA1
2	down(ON)	Disable ENA2 functionality. Connects internally +V _{LOG} to ENA2
3	down(ON)	Connect an 120Ω resistor between Z1+ and Z1- feedback pins
4	down(ON)	Connect an 120Ω resistor between B1+ and B1- feedback pins
5	down(ON)	Connect an 120Ω resistor between A1+ and A1- feedback pins
6	down(ON)	
7	down(ON)	Reserved; leave always in down position (ON) for correct operation of the Enable circuit.
8	down(ON)	

Electrical characteristics

All parameters measured under the following conditions (unless otherwise specified):

- V_{LOG} = 24 VDC; V_{MOT} = 48VDC
- Supplies start-up / shutdown sequence: -any-
- Load current (sinusoidal amplitude / continuous BLDC, DC, stepper) = 8A

Operating Conditions		Min.	Typ.	Max.	Units
Ambient temperature		0		40 ^{1,3}	°C
Ambient humidity	Non-condensing	0		90	%Rh
Altitude / pressure ²	Altitude (vs. sea level)	-0.1	0 ± 2.5	²	Km
	Ambient Pressure	0 ²	0.75 ± 1	10.0	atm
Storage Conditions		Min.	Typ.	Max.	Units
Ambient temperature		-40		105	°C
Ambient humidity	Non-condensing	0		100	%Rh
Ambient Pressure		0		10.0	atm
ESD capability (Human body model)	Not powered; applies to any accessible part			±0.5	kV
	Original packaging			±15	kV
Mechanical Mounting		Min.	Typ.	Max.	Units
Airflow	natural convection ³ , closed box				
Environmental Characteristics		Min.	Typ.	Max.	Units
Size (Length x Width x Height)	Without mating connectors	103 x 71 x 16.4			mm
	With recommended mating connectors	~4.06 x 2.8 x 0.65			inch
Weight	Without mating connectors	125			g
	With recommended mating connectors	~4.3 x 3.1 x 0.77			inch
Power dissipation	Idle (no load)	3.4			W
	Operating	8.5			W
Efficiency		98			%
Cleaning agents	Dry cleaning is recommended	Only Water- or Alcohol- based			
Protection degree	According to IEC60529, UL508	IP20			-

Logic Supply Input (+V _{LOG})		Min.	Typ.	Max.	Units
Supply voltage	Nominal values	9		36	V _{DC}
	Absolute maximum values, drive operating but outside guaranteed parameters	8		40	V _{DC}
	Absolute maximum values, surge (duration ≤ 10ms) [†]	-1		+45	V
Supply current	No Load on Digital Outputs	+V _{LOG} = 9V		400	mA
		+V _{LOG} = 12V		300	
		+V _{LOG} = 24V		150	
		+V _{LOG} = 39V		90	
Motor Supply Input (+V _{MOT})		Min.	Typ.	Max.	Units
Supply voltage	Nominal values	11		50	V _{DC}
	Absolute maximum values, drive operating but outside guaranteed parameters	9		52	V _{DC}
	Absolute maximum values, continuous	-0.6		54	V _{DC}
Supply current	Absolute maximum values, surge (duration ≤ 10ms) [†]	-1		+57	V
	Idle		1	5	mA
	Operating	-20	±8	+20	A
Nominal output current, continuous ⁴	for DC brushed, steppers and BLDC motors with Hall-based trapezoidal control			8	A
	for PMSM motors with FOC sinusoidal control (sinusoidal amplitude value)			8	
	for PMSM motors with FOC sinusoidal control (sinusoidal effective value)			5.66	
Motor output current, peak	maximum 2.5s	-20		+20	A
Short-circuit protection threshold		±22	±26	±30	A
Short-circuit protection delay		5	10		µs
On-state voltage drop	Nominal output current; including typical mating connector contact resistance		±0.3	±0.5	V
Off-state leakage current			±0.5	±1	mA
Motor inductance (phase-to-phase)	Recommended value, for current ripple max. ±5% of full range; +V _{MOT} = 36 V	F _{PWM}			µH
		20 kHz	330		
		40 kHz	150		
		60 kHz	120		
		80 kHz	80		
	Minimum value, limited by short-circuit protection; +V _{MOT} = 36 V	20 kHz	120		µH
		60 kHz	40		
		40 kHz	30		
		80 kHz	15		
		100 kHz	8		
Motor electrical time-constant (L/R)	Recommended value for ±5% current measurement error	20 kHz	250		µs
		40 kHz	125		
		60 kHz	100		
		80 kHz	63		
		100 kHz	50		
Current measurement	FS = Full Scale accuracy		±4	±8	%FS
Digital Hall Inputs (Hall1, Hall2, Hall3)		Min.	Typ.	Max.	Units
Mode compliance		TTL / CMOS / Open-collector			
Default state	Input floating (wiring disconnected)	Logic HIGH			
Input voltage	Logic "LOW"		0	0.8	V
	Logic "HIGH"	2	5		
	Floating voltage (not connected)		4.4		
	Absolute maximum, surge (duration ≤ 1s) [†]	-10		+15	
Input current	Logic "LOW"; Pull to GND			5	mA
	Logic "HIGH"; Internal 1KΩ pull-up to +5V	0	0	0	
Minimum pulse width		2			µs
ESD protection		Human body model		±5	kV

¹ Operating temperature at higher temperatures is possible with reduced current and power ratings

² iPOS4808 can be operated in vacuum (no altitude restriction), but at altitudes over 2,500m, current and power rating are reduced due to thermal dissipation efficiency.

³ In case of forced cooling (conduction or ventilation) the maximum ambient temperature can be increased substantially.

⁴ @20KHz F_{PWM}

Name	First edition	Document template: P099.TQT.564.0001	Last edition	Visa :
EP	January 12, 2018		May 28, 2024	AN
TECHNOSOFT		Title of document	N° document	
		iPOS4808 BX-CAT	P027.214.E221.DSH.10G	
		PRODUCT DATA SHEET	Page: 3 of 5	



iPOS4808 BX-CAT DATASHEET

P/N: P027.214.E221

Digital Inputs (IN0, IN1, IN2/LSP, IN3/LSN, IN5, IN6) ¹		Min.	Typ.	Max.	Units
Mode compliance		PNP			
Default state	Input floating (wiring disconnected)	Logic LOW			
Input voltage	Logic "LOW"	-36	0	2.4	V
	Logic "HIGH"	7.5	24	36	
	Hysteresis	1.2	2.4	2.8	
	Floating voltage (not connected)	0			
	Absolute maximum, continuous	-36	+39		
Input current	Logic "LOW"; pulled to GND	0			mA
	Logic "HIGH"; pulled to +24V	8			
Mode compliance		NPN			
Default state	Input floating (wiring disconnected)	Logic HIGH			
Input voltage	Logic "LOW"	0			V
	Logic "HIGH"	1.8	24	39	
	Hysteresis	1.2	2.4	2.8	
	Floating voltage (not connected)	15			
	Absolute maximum, continuous	-10	+39		
Input current	Logic "LOW"; Pulled to GND	8			mA
	Logic "HIGH"; Internal 12KΩ pull-up to +Vlog	0			
Input frequency		0			kHz
Minimum pulse width		6			μs
ESD protection - Human body model		±5			kV
Encoder2 Inputs (A2+/Data+, A2-/Data-, B2+/Clk+, B2-/Clk-, Z2+, Z2-)		Min.	Typ.	Max.	Units
Differential mode compliance TIA/EIA-422-A					
Input voltage	Hysteresis	±0.06	±0.1	±0.2	V
	Differential mode	-14	+14		
	Common-mode range (A+ to GND, etc.)	-11	+14		
Input impedance, differential	A2+, B2+, Z2+, A2-, B2-, Z2-	120			Ω
Input frequency	Differential mode	0			MHz
Minimum pulse width	Differential mode	50			ns
Analog 0...5V Inputs (REF, FDBK)		Min.	Typ.	Max.	Units
Input voltage	Operational range	0			V
	Absolute maximum values, continuous	-12			
	Absolute maximum, surge (duration ≤ 1s) [†]	±36			
Input impedance	To GND	27			kΩ
Resolution		12			bits
Integral linearity		±2			bits
Offset error		±2			bits
Gain error		±1%			% FS ²
Bandwidth (-3Db)	Software selectable	0			kHz
ESD protection	Human body model	±5			kV
Sin-Cos Encoder Inputs (Sin+, Sin-, Cos+, Cos-)		Min.	Typ.	Max.	Units
Input voltage, differential	Sin+ to Sin-, Cos+ to Cos-	1			V _{pp}
Input voltage, any pin to GND	Operational range	-1	2.5	4	V
	Absolute maximum values, continuous	-7			
	Absolute maximum, surge (duration ≤ 1s) [†]	-11			
Input impedance	Differential, Sin+ to Sin-, Cos+ to Cos- ³	4.2	4.7	kΩ	
	Common-mode, to GND	2.2			kΩ
Resolution with interpolation	Software selectable, for one sine/cosine period	2			bits
Frequency	Sin-Cos interpolation	0			kHz
	Quadrature, no interpolation	0			MHz
ESD protection	Human body model	±1			kV

Digital Outputs (OUT0, OUT1, OUT2/Error, OUT3/Ready, OUT4)		Min.	Typ.	Max.	Units	
Mode compliance	All outputs (OUT0, OUT1, OUT2/Error, OUT3/Ready)	TTL / open-collector / NPN 24V				
Default state	Not supplied (+V _{Log} floating or to GND)	High-Z (floating)				
	Immediately after power-up	OUT0, OUT1, OUT4	Logic "HIGH"			
	Normal operation	OUT2/Error, OUT3/Ready	Logic "LOW"			
Output voltage	Logic "LOW"; output current = 0.5A	OUT0, OUT1, OUT4	2.9	3	3.3	V
		Logic "HIGH"; output current = 0, no load	4	4.5	5	
	Logic "HIGH", external load to +V _{Log}	V _{Log}				
	Absolute maximum, continuous	-0.5				
	Absolute maximum, surge (duration ≤ 1s) [†]	-1				
Output current	Logic "LOW", sink current	0.5			A	
	Logic "LOW", sink current, pulse ≤ 5 sec.	1			A	
	Logic "HIGH", source current; external load to GND; V _{OUT} ≥ 2.0V	OUT2/Error, OUT3/Ready	2			mA
		OUT0, OUT1, OUT4	4			mA
	Logic "HIGH", leakage current; external load to +V _{Log} ; V _{OUT} = V _{Log} max = 40V	0.1			0.2	mA
Minimum pulse width	2			μs		
ESD protection - Human body model	±15			kV		
Encoder1 Inputs (A1/A1+, A1-, B1/B1+, B1-, Z1/Z1+, Z1-)		Min.	Typ.	Max.	Units	
Single-ended mode compliance	Leave negative inputs disconnected	TTL / CMOS / Open-collector				
Input voltage, single-ended mode A/A+, B/B+	Logic "LOW"	1.6			V	
	Logic "HIGH"	1.8				
Input voltage, single-ended mode Z/Z+	Floating voltage (not connected)	3.3			V	
	Logic "LOW"	1.2				
Input current, single-ended mode A/A+, B/B+, Z/Z+	Logic "HIGH"	1.4			mA	
	Floating voltage (not connected)	4.7				
Differential mode compliance	Logic "LOW"; Pull to GND	5.5			mA	
	Logic "HIGH"; Internal 2.2KΩ pull-up to +5	0				
For full RS422 compliance, see ⁴	TIA/EIA-422-A					
Input voltage, differential mode	Hysteresis	±0.06	±0.1	±0.2	V	
	Common-mode range (A+ to GND, etc.)	-7				
Input impedance, differential	A1+ to A1-, B1+ to B1-, Z1+ to Z1-	1			kΩ	
Input frequency	Single-ended mode, Open-collector / NPN	0			MHz	
	Differential mode, or Single-ended driven by push-pull (TTL / CMOS)	5				
Minimum pulse width	Single-ended mode, Open-collector / NPN	1			μs	
	Differential mode, or Single-ended driven by push-pull (TTL / CMOS)	10				
Input voltage, any pin to GND	Absolute maximum values, continuous	-7			V	
	Absolute maximum, surge (duration ≤ 1s) [†]	-11				
ESD protection	Human body model	±1			kV	
RS-232		Min.	Typ.	Max.	Units	
Compliance	TIA/EIA-232-C					
Bit rate	Software selectable	9600	115200		Baud	
Short-circuit	232TX short to GND	Guaranteed				
ESD protection	Human body model	±2			kV	

¹ The digital inputs are software selectable as PNP or NPN

² "FS" stands for "Full Scale"

³ For many applications, a 120Ω termination resistor should be connected across SIN+ to SIN-, and across COS+ to COS- (set SW3 switches 3 and 4 to ON). Please consult the feedback device datasheet for confirmation.

⁴ For full RS-422 compliance, 120Ω termination resistors must be connected across the differential pairs, set SW3 pins 3,4 and 5 to ON.

Name	First edition	Document template: P099.TQT.564.0001	Last edition	Visa :
EP	January 12, 2018		May 28, 2024	AN
		Title of document	N° document	
		iPOS4808 BX-CAT	P027.214.E221.DSH.10G	
		PRODUCT DATA SHEET		Page: 4 of 5



iPOS4808 BX-CAT DATASHEET

P/N: P027.214.E221

Enable circuit (ENA1, ENA2)		Min.	Typ.	Max.	Units
Enable function	Disables motor power when either ENA1 or ENA2 is disconnected from the power source				
Mode compliance	PNP				
Default state	Input floating (wiring disconnected)	Logic LOW			
Input voltage	Logic "LOW" (PWM operation disabled)	-20		5.6	V
	Logic "HIGH" (PWM operation enabled)	18		36	
	Absolute maximum, continuous	-20		+40	
Input current	Logic "LOW"; pulled to GND		0		mA
	Logic "HIGH"; pulled to +Vlog		5	13	
Pulse duration	Ignored high-low-high			5	ms
	Accepted pulse			20	Hz
PWM operation delay	From Enabled low-high transition to PWM operation enabled			30	ms
ESD protection	Human body model	±2			kV
Supply Output (+5V)		Min.	Typ.	Max.	Units
Output voltage	Current sourced = 250mA	4.8	5.15	5.25	V
Output current		200	250		mA
Short-circuit	NOT protected				
Over-voltage	NOT protected				
ESD protection	Human body model	±1			kV

† Stresses beyond values listed under "absolute maximum ratings" may cause permanent damage to the device. Exposure to absolute-maximum-rated conditions for extended periods may affect device reliability.

Name EP	First edition January 12, 2018	Document template: P099.TQT.564.0001	Last edition May 28, 2024	Visa : AN
		Title of document iPOS4808 BX-CAT PRODUCT DATA SHEET	N° document P027.214.E221.DSH.10G Page: 5 of 5	