

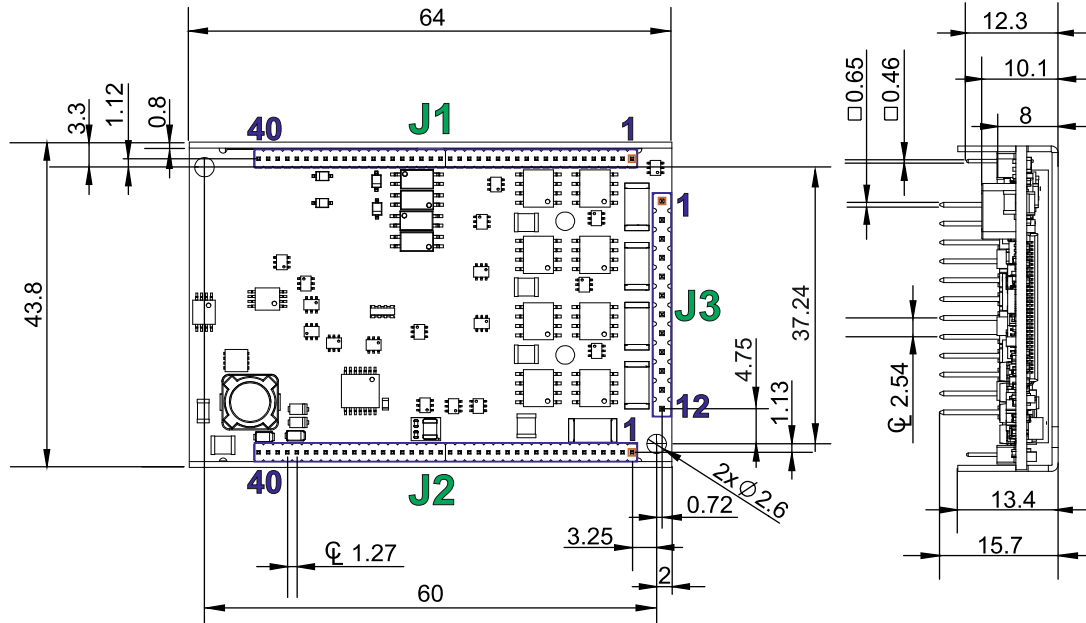

iPOS4815 MZ-CAT DATASHEET

P/N: P022.016.E122



Top view; Pins facing upward; All dimensions are in mm; Header pitch of J1 & J2 is 1.27mm and for J3 is 2.54 mm. Drawing not to scale. The free area around the mounting holes (free of components or other copper features) has a 5.5mm diameter.

Motor – sensor configurations

Sensor \ Motor	PMSM	BLDC	DC BRUSH	STEP (2-ph)	STEP (3-ph)
Incr. Encoder	Ⓢ		Ⓢ	Ⓢ	
Incr. Encoder + Dig. Hall	Ⓢ	Ⓢ			
Linear Halls	Ⓢ				
Digital Hall control only	Ⓢ				
Analog Sin/Cos encoder	Ⓢ	Ⓢ	Ⓢ	Ⓢ	
SSI / BiSS-C/ EnDAT/ TAMAGAWA/ Panasonic/ Nikon / Sanyo Denki	Ⓢ	Ⓢ	Ⓢ	Ⓢ	
Tacho			Ⓢ		
Open-loop (no sensor)				Ⓢ	Ⓢ

Features

- Motion controller and drive in a single compact unit based on MotionChip™ technology
- Universal solution for control of rotary and linear brushless, brushed and 2 or 3-phase step motors
- Advanced motion control capabilities (PVT, S-curve, electronic cam)
- Motor supply: 11-50V; Logic SELV/ PELV supply: 9-36V; STO SELV/ PELV supply: 18-40V
- Motor output current:
 - Nominal: 15A_{RMS} / 21.2A amplitude;
 - Peak: 28.3A_{RMS} / 40A amplitude.
- Operating ambient temperature: 0-40°C (over 40°C with derating)
- NTC/PTC analogue Motor Temperature sensor input
- Communication interfaces:
 - USB
 - LV-TTL UART (RS-232 with external transceiver)

- dual 100Mbps EtherCAT® ports
- Feedback Devices (dual-loop support)
 - 1st feedback devices supported:
 - Incremental encoder interface (single ended or differential)
 - Analogue sin/cos encoder interface (differential 1V_{pp})
 - Digital Hall sensor interface (single-ended and open collector)
 - Linear Hall sensors interface
 - 2nd feedback devices supported:
 - Incremental encoder interface (differential)
 - SSI / BiSS-C/ EnDAT/ TAMAGAWA/ Panasonic/ Nikon/ Sanyo Denki encoder interface
- Pulse & direction reference (single-ended or differential) capability
- STO: 2 safe torque-off inputs, safety integrity level (SIL3/Cat3/PLe) acc. to EN61800-5-1; -2/ EN61508-3; -4/ EN ISO 13849-1.
- 6 x digital inputs, 12-36V, PNP/NPN software selectable: 2 x for limit switches or general-purpose, 4 x general-purpose
- 5 x digital outputs, 5-36V: 0.4A NPN / 0.3A PNP, polarity software selectable: Ready, Error or general-purpose
- 1 x dedicated motor brake or general-purpose output (OUT0): 2A NPN / 1.5A PNP, polarity software selectable
- 2 x analogue inputs software selectable: 12-bit 0-5V: Reference, Feedback or general-purpose
- Commissioning (set-up) possible through RS232, FoE (file-over-EtherCAT®), EoE (Ethernet-over-EtherCAT®)
- EtherCAT® connection between multiple MZ drives: direct 1:1 without any series components
- EtherCAT® connection to standard RJ45: requires external magnetics (may be integrated into RJ45)
- 255 h/w addresses selectable by h/w pins configuration
- 16k x 16 SRAM memory for data acquisition
- 24k x16 E²ROM to store setup data, TML motion programs, cam tables and other user data

Name ALN	First edition May 4, 2021	Document template: P099.TQT.564.0001	Last edition October 31, 2023	Visa: AS, AN
		Title of document iPOS4815 MZ-CAT PRODUCT DATA SHEET	N° document P022.016.E122.DSH.011	
			Page: 1 of 7	

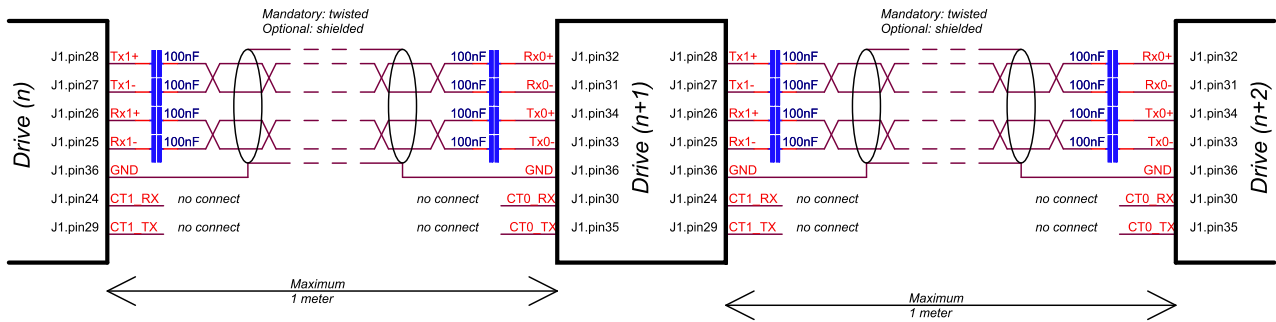
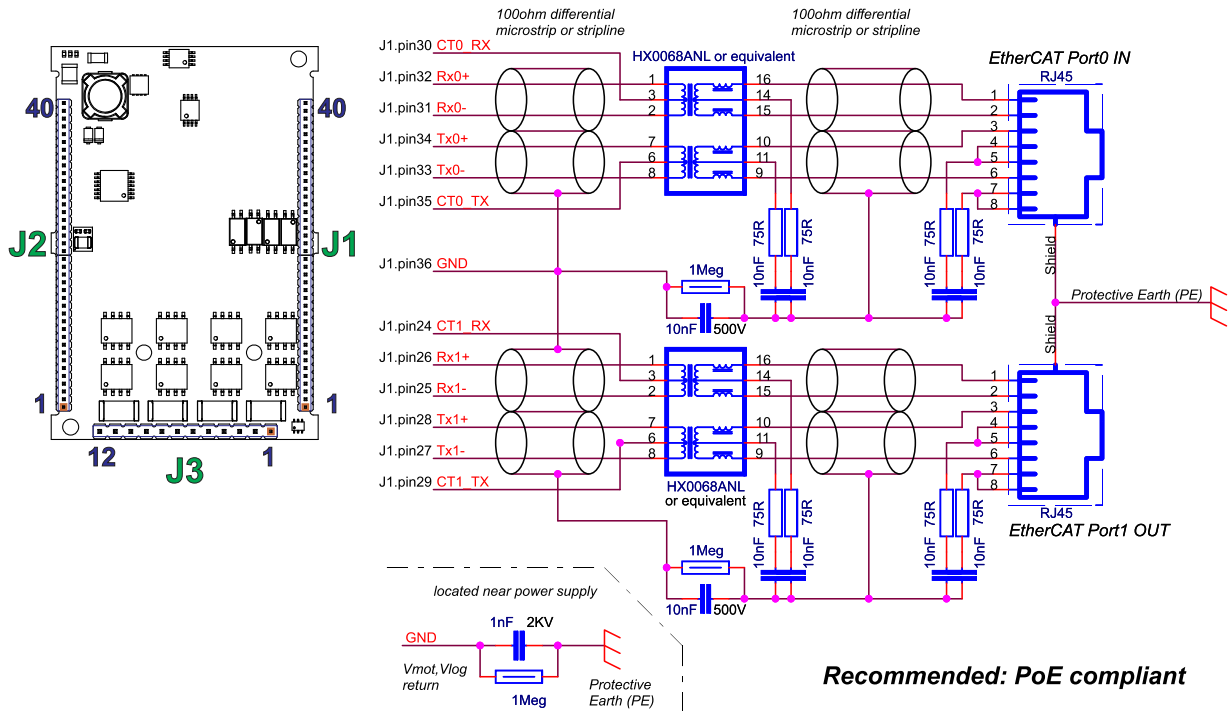

Mandatory: all drives supplied from the same power supply same GND)

Alternative: Direct connection

Mating Connectors			
When J3 is plugged into a connector and maximum current should not exceed 12.7A Sine amplitude			
Ref	Producer	Part No.	Description
J1, J2	Harwin	M52-5012045	1x20 contacts, socket 1.27mm-pitch; 4 pcs needed for one drive
	Samtec	SMS-140-01-L-S SMS-140-01-G-S	1x40 contacts, socket 1.27mm-pitch; 2 pcs needed for one drive
J3	Mill-Max	801-47-012-10-001000	1x12 contacts, High-current socket 2.54mm-pitch accepting 0.635mm square pin; 1 pcs is needed for one drive; the current should not exceed 12.7A
When J3 is soldered directly onto a motherboard and the maximum current can exceed 13A Sine amplitude			
Ref	Producer	Part No.	Description
J1, J2	Harwin	M52-5012045	1x20 contacts, socket 1.27mm-pitch; 4 pcs needed for one drive
J3	The pins are directly soldered onto a motherboard for increased current capability		

Pin	Name	Type	Description
1,2	GND	-	Return ground for motor. Internally connected to all GND signals except STO GND.
3,4	Cr/B-	O	Chopping resistor / Phase B- for 2-ph steppers
5,6	C/B+	O	Phase C for 3-ph motors, B+ for 2-ph steppers
7,8	B/A-	O	Phase B for 3-ph motors, A- for 2-ph steppers, Motor- for DC brush motors
			Phase A for 3-ph motors, A+ for 2-ph steppers, Motor+ for DC brush motors
11,12	+V _{MOT}	I	Positive terminal of the motor supply: 11 to 48V _{DC} .



iPOS4815 MZ-CAT DATASHEET

P/N: P022.016.E122

Pin	Name	Type	Description
1	Temp Mot	I	NTC/PTC 3.3V input. Used to read an analog temperature value
2	TTL TX	O	Low voltage TTL UART data transmission
3	TTL RX	I	Low voltage TTL UART data reception
4	USB Data-	I/O	USB Data negative
5	USB Data+	I/O	USB Data positive
6	USB V+	I	USB +5V input
7	P1 LED	O	ECAT OUT port LED
8	P0 LED	O	ECAT IN port LED
9	Axis ID Bit7	I	8-bit H/W Axis ID register. Pin 16 is Bit 0... Pin 9 is Bit 7 of the Axis value. • Bit = 0, if pin is left unconnected. • Bit = 1, if pin is connected to GND. AxisID values: from 1 to 255. AxisID = 255 also when all pins are left unconnected. In EtherCAT, when Axis ID is 255, the register called "configured station alias" will be 0.
10	Axis ID Bit6	I	
11	Axis ID Bit5	I	
12	Axis ID Bit4	I	
13	Axis ID Bit3	I	
14	Axis ID Bit2	I	
15	Axis ID Bit1	I	
16	Axis ID Bit0	I	
17	RUN	O	Anode of Run LED (EtherCAT status machine).
18	ERR	O	Anode of Error LED (EtherCAT status machine).
19	Spi2 Clk	O	Reserved. Do not use
20	Spi2 Out	O	Reserved. Do not use
21	Spi2 In	I	Reserved. Do not use
22	Spi2 CS	O	Reserved. Do not use
23	Spi2 Irq	I	Reserved. Do not use
24	CT1_Rx	-	Connect to center tap of OUT port magnetics PHY Rx.
25	RX1-	I/O	Receive/Transmit negative, OUT port. Connect to magnetics PHY RX1.
26	RX1+	I/O	Receive/Transmit positive, OUT port. Connect to magnetics PHY RX1.
27	TX1-	I/O	Transmit/Receive negative, OUT port. Connect to magnetics PHY TX1.
28	TX1+	I/O	Transmit/Receive positive, OUT port. Connect to magnetics PHY TX1.
29	CT1_Tx	-	Connect to center tap of OUT port magnetics PHY Tx.
30	CT0_Rx	-	Connect to center tap of IN port magnetics PHY Rx.
31	RX0-	I/O	Receive/Transmit negative, IN port. Connect to magnetics PHY RX0.
32	RX0+	I/O	Receive/Transmit positive, IN port. Connect to magnetics PHY RX0.
33	TX0-	I/O	Transmit/Receive negative, IN port. Connect to magnetics PHY TX0.
34	TX0+	I/O	Transmit/Receive positive, IN port. Connect to magnetics PHY TX0.
35	CT0_Tx	-	Connect to center tap of IN port magnetics PHY Tx.
36	GND	-	Return ground. Internally connected to all GND signals except STO GND.
37	STO2-	I	Safe Torque Off input 2, negative return (opto-isolated, 0V)
38	STO2+	I	Safe Torque Off input 2, positive input (opto-isolated, 18+40V)
39	STO1-	I	Safe Torque Off input 1, negative return (opto-isolated, 0V)
40	STO1+	I	Safe Torque Off input 1, positive input (opto-isolated, 18+40V)

Apply between both STO1+, STO2+ and STO1-, STO2- 24V DC from SELV/ PELV power supply for motor PWM output operation

Pin	Name	Type	Description
1	LH1	I	Linear Hall 1 input
2	LH2	I	Linear Hall 2 input
3	LH3	I	Linear Hall 3 input
4	FDBK	I	Analogue input, 12-bit, 0-5V. Reads analogue feedback (tacho), or general purpose
5	REF	I	Analogue input, 12-bit, 0-5V. Reads analog reference, or general-purpose analogue input
6	Hall 3	I	Digital input Hall 3 sensor
7	Hall 2	I	Digital input Hall 2 sensor
8	Hall 1	I	Digital input Hall 1 sensor
9	GND	-	Return ground. Internally connected to all GND signals except STO GND.
10	IN5	I	12-36V general-purpose digital PNP/NPN input
11	IN4	I	12-36V general-purpose digital PNP/NPN input
12	IN1	I	12-36V general-purpose digital PNP/NPN input
13	IN0	I	12-36V general-purpose digital PNP/NPN input
14	IN2/LSP	I	12-36V digital PNP/NPN input. Positive limit switch input
15	IN3/LSN	I	12-36V digital PNP/NPN input. Negative limit switch input
16	OUT3	O	5-36V general-purpose digital output, 0.3A PNP/ 0.4A NPN, software selectable
17	OUT2	O	5-36V general-purpose digital output, 0.3A PNP/ 0.4A NPN, software selectable
18	OUT5	O	5-36V general-purpose digital output, 0.3A PNP/ 0.4A NPN, software selectable
19	OUT4	O	5-36V general-purpose digital output, 0.3A PNP/ 0.4A NPN, software selectable
20	OUT1	O	5-36V general-purpose digital output, 0.3A PNP/ 0.4A NPN, software selectable
21	OUT0	O	5-36V general-purpose digital output, 1.5A PNP/ 2A NPN, software selectable
22	Z1+	I	Incr. encoder1 Z single-ended, or Z+ diff. input,
23	Z1-	I	Incr. encoder1 Z- diff. input
24	B1+/Cos+	I	Incr. encoder1 B single-ended, or B+ diff. input, or analogue encoder Cos+ diff. input
25	B1-/Cos-	I	Incr. encoder1 B- diff. input, or analogue encoder Cos- diff. input
26	A1+/Sin+	I	Incr. encoder1 A single-ended, or A+ diff. input, or analogue encoder Sin+ diff. input
27	A1-/Sin-	I	Incr. encoder1 A- diff. input, or analogue encoder Sin- diff. input
28	Z2+	I	Incr. encoder2 Z+ diff. input; has 120Ω resistor between pins 28 and 29
29	Z2-	I	Incr. encoder2 Z- diff. input; has 120Ω resistor between pins 28 and 29
30	B2-/Dir-/CLK-/MA-	I/O	Incr. encoder2 B- diff. input, or Dir-, or Clock- for SSI, or Master- for BiSS; has 120Ω resistor between pins 30 and 31
31	B2+/Dir+/CLK+/MA+	I/O	Incr. encoder2 B+ diff. input, or Dir+, or Clock+ for SSI, or Master+ for BiSS; has 120Ω resistor between pins 30 and 31
32	A2+/Pulse+/Data+/SL+	I	Incr. encoder2 A+ diff. input, or Pulse+, or Data+ for SSI, or Slave+ for BiSS; has 120Ω resistor between pins 32 and 33
33	A2-/Pulse-/Data-/SL-	I	Incr. encoder2 A- diff. input, or Pulse-, or Data- for SSI, or Slave- for BiSS; has 120Ω resistor between pins 32 and 33
34	Reserved	-	Reserved. Do not use
35	Reserved	-	Reserved. Do not use
36	Reserved	-	Reserved. Do not use
37	Reserved	-	Reserved. Do not use
38	+5V _{OUT}	O	5V output supply for I/O usage
39	-V _{LOG}	I	Negative terminal of the logic supply input: 9 to 36V _{DC} from SELV/ PELV type power supply.
40	+V _{LOG}	I	Positive terminal of the logic supply input: 9 to 36V _{DC} from SELV/ PELV type power supply.

Name ALN	First edition May 4, 2021	Document template: P099.TQT.564.0001	Last edition October 31, 2023	Visa: AS, AN
 TECHNOSOFT		Title of document iPOS4815 MZ-CAT PRODUCT DATA SHEET	N° document P022.016.E122.DSH.011 Page: 3 of 7	



iPOS4815 MZ-CAT DATASHEET

P/N: P022.016.E122

Electrical characteristics

All parameters measured under the following conditions (unless otherwise specified):

- $V_{LOG} = 24 \text{ VDC}$; $V_{MOT} = 48 \text{ VDC}$; $F_{PWM} = 20 \text{ kHz}$
- Supplies start-up / shutdown sequence: -any-
- Load current (sinusoidal amplitude) = 21.2 A

Operating Conditions		Min.	Typ.	Max.	Units
Ambient temperature		0		40 ¹	°C
Ambient humidity	Non-condensing	0		90	%Rh
Altitude / pressure ²	Altitude (vs. sea level)	-0.1	0 + 2.5	2	Km
	Ambient Pressure	0 ²	0.75 + 1	10.0	atm
Storage Conditions		Min.	Typ.	Max.	Units
Ambient temperature		-40		100	°C
Ambient humidity	Non-condensing	0		100	%Rh
Ambient Pressure		0		10.0	atm
ESD capability (Human body model)	Not powered; applies to any accessible part			±0.5	kV
	Original packaging			±15	kV
Mechanical Mounting		Min.	Typ.	Max.	Units
Airflow		natural convection ³ , closed box			
Spacing required for vertical mounting	Between adjacent drives	30			mm
	Between drives and nearby walls	30			mm
	Between drives and roof-top	20			mm
Spacing required for horizontal mounting	Between adjacent drives	4			mm
	Between drives and nearby walls	5			mm
	Space needed for drive removal	10			mm
	Between drives and roof-top	15			mm
Insertion force	Using recommended mating connectors		12	8	N
Extraction force		8	10		N
Environmental Characteristics		Min.	Typ.	Max.	Units
Size (Length x Width x Height)	Global size	64 x 43.8 x 15.7			mm
		~2.52 x 1.72 x 0.62			inch
Weight		~34			g
Cleaning agents	Dry cleaning is recommended	Only Water- or Alcohol- based			
Protection degree	According to IEC60529, UL508	IP20			
Logic Supply Input (+V _{LOG})		Min.	Typ.	Max.	Units
Supply voltage	Nominal values	9		36	V _{DC}
	Absolute maximum values, drive operating but outside guaranteed parameters	8		40	V _{DC}
	Absolute maximum values, continuous	-0.6		42	V _{DC}
	Absolute maximum values, surge (duration ≤ 10ms) [†]	-1		+45	V
Supply current	+V _{LOG} = 12V		150		mA
	+V _{LOG} = 24V		100		
	+V _{LOG} = 40V		80		
Motor Supply Input (+V _{MOT})		Min.	Typ.	Max.	Units
Supply voltage	Nominal values	11		50	V _{DC}
	Absolute maximum values, drive operating but outside guaranteed parameters	9		52	V _{DC}
	Absolute maximum values, continuous	-0.6		54	V _{DC}
	Absolute maximum values, surge (duration ≤ 10ms) [†]	-1		57	V
Supply current	Idle		1	5	mA
	Operating	-40	±10	+40	
	Absolute maximum value, short circuit condition (duration ≤ 10ms) [†]			43	
Supply Output (+5V)		Min.	Typ.	Max.	Units
Output voltage	Current sourced = 250mA	4.95	5.11	5.25	V
Output current		360	450		mA
Short-circuit		NOT protected			
Over-voltage		NOT protected			
ESD protection	Human body model	±1			kV
Isolation PE (earth) – GND				±250	V

Motor Outputs (A/A+, B/A-, C/B+, CR/B-)		Min.	Typ.	Max.	Units
Nominal current	PMSM motors sinusoidal amplitude			21.2	A
	PMSM motors sinusoidal RMS			15	A _{RMS}
	DC/BLDC motors continuous			18.3	A
Peak current	maximum 12.5 s	-40		+40	A
Short-circuit protection threshold		±43		±43	A
Short-circuit protection delay		3.3			µs
On-state voltage drop	Nominal output current; including typical mating connector contact resistance		0.15		V
Voltage efficiency			100		%
Off-state leakage current			±0.5	±1	mA
Motor inductance (phase-to-phase)	Recommended value, for current ripple max. ±5% of full range; +V _{MOT} = 36 V	F _{PWM}			µH
		20 kHz	400		
		40 kHz	200		
		60 kHz	150		
		80 kHz	100		
	Minimum value, limited by short-circuit protection; +V _{MOT} = 36 V	20 kHz	150		µH
		60 kHz	50		
		40 kHz	40		
		80 kHz	20		
		100 kHz	10		
Motor electrical time-constant (L/R)	Recommended value for ±5% current measurement error	20 kHz	330		µs
		40 kHz	170		
		60 kHz	140		
		80 kHz	80		
		100 kHz	66		
Current measurement	FS = Full Scale accuracy	-9.3	+/- 3.4	+9.3	%FS
Digital Hall Inputs (Hall1, Hall2, Hall3)		Min.	Typ.	Max.	Units
Mode compliance		TTL / CMOS / Open-collector			
Default state	Input floating (Wiring disconnected)	Logic HIGH			
Input voltage	Logic "LOW"		0	0.8	V
	Logic "HIGH"	2	5		
	Floating voltage (Not connected)		4.4		
	Absolute maximum, surge (duration ≤ 1s) [†]	-10		+15	
Input current	Logic "LOW"; Pull to GND			1.2	mA
	Logic "HIGH"; Internal 4.7KΩ pull-up to +5	0	0	0	
Minimum pulse width		2			µs
ESD protection	Human body model	±5			kV
Linear Hall Inputs (LH1, LH2, LH3)		Min.	Typ.	Max.	Units
Input voltage	Operational range	0	0.5+4.5	4.9	V
	Absolute maximum values, continuous	-7		+7	V
Input voltage	Absolute maximum, surge (duration ≤ 1s) [†]	-11		+14	
	Input current	Input voltage 0...+5V	0		0.2
Interpolation Resolution	Depending on software settings			11	bits
Frequency		0		1	kHz
ESD protection	Human body model	±1			kV
Digital Inputs (IN0, IN1, IN2/LSP, IN3/LSN, IN4, IN5, IN6) [‡]		Min.	Typ.	Max.	Units
Mode compliance		PNP			
Default state	Input floating (wiring disconnected)	Logic LOW			
Input voltage	Logic "LOW"	-10	0	2.2	V
	Logic "HIGH"	6.3	24	36	
	Hysteresis	1.2	2.4	2.8	
	Floating voltage (not connected)		0		
	Absolute maximum, continuous	-10		+39	
	Absolute maximum, surge (duration ≤ 1s) [†]	-20		+40	
Input current	Logic "LOW"; pulled to GND		0		mA
	Logic "HIGH"		8	10	

¹ Operating temperature at higher temperatures is possible with reduced current and power ratings

² iPOS4810 can be operated in vacuum (no altitude restriction), but at altitudes over 2,500m, current and power rating are reduced due to thermal dissipation efficiency.

³ In case of forced cooling (conduction or ventilation) the spacing requirements may drop substantially down to zero as long as the ambient temperature is kept below the maximum operating limit

⁴ The digital inputs and outputs are software selectable as PNP or NPN

Name ALN	First edition May 4, 2021	Document template: P099.TQT.564.0001	Last edition October 31, 2023	Visa: AS, AN
TECHNOSOFT		Title of document iPOS4815 MZ-CAT PRODUCT DATA SHEET	N° document P022.016.E122.DSH.011	
				Page: 4 of 7



iPOS4815 MZ-CAT DATASHEET

P/N: P022.016.E122

Mode compliance		NPN			
Default state	Input floating (wiring disconnected)	Logic HIGH			
Input voltage	Logic "LOW"		0	2.2	V
	Logic "HIGH"	6.3	24	36	
	Hysteresis	1.2	2.4	2.8	
	Floating voltage (not connected)		15		
	Absolute maximum, continuous	-10		+39	
	Absolute maximum, surge (duration ≤ 1s) [†]	-20		+40	
Input current	Logic "LOW"; Pulled to GND		8	10	mA
	Logic "HIGH"; Pulled to +24V	0	0	0	
Input frequency		0		10	kHz
Minimum pulse		6			µs
ESD protection	Human body model	±5			kV
Encoder1 Inputs (A1/A1+, A1-, B1/B1+, B1-, Z1/Z1+, Z1-)		Min.	Typ.	Max.	Units
Single-ended mode compliance	Leave negative inputs disconnected	TTL / CMOS / Open-collector			
Input voltage, single-ended mode A/A+, B/B+	Logic "LOW"			1.6	V
	Logic "HIGH"	1.8			
	Floating voltage (not connected)		3.3		
Input voltage, single-ended mode Z/Z+	Logic "LOW"			1.2	V
	Logic "HIGH"	1.4			
	Floating voltage (not connected)		4.7		
Input current, single-ended mode A/A+, B/B+, Z/Z+	Logic "LOW"; Pull to GND		5.5	6	mA
	Logic "HIGH"; Internal 2.2KΩ pull-up to +5	0	0	0	
Differential mode compliance	For full RS422 compliance, see ¹	TIA/EIA-422-A			
Input voltage, differential mode	Hysteresis	±0.06	±0.1	±0.2	V
	Common-mode range (A+ to GND, etc.)	-7		+7	
Input impedance, differential	A1+ to A1-, B1+ to B1-		1		kΩ
	Z1+ to Z1-		1		
Input frequency	Single-ended mode, Open-collector / NPN	0		5	MHz
	Differential mode, or Single-ended driven by push-pull (TTL / CMOS)	0		10	
Minimum pulse width	Single-ended mode, Open-collector / NPN	1			µs
	Differential mode, or Single-ended driven by push-pull (TTL / CMOS)	50			
Input voltage, any pin to GND	Absolute maximum values, continuous	-7		+7	V
	Absolute maximum, surge (duration ≤ 1s) [†]	-11		+14	
ESD protection	Human body model	±1			kV
Digital Outputs (OUT1, OUT2/Error, OUT3/Ready, OUT4, OUT5)²		Min	Typ.	Max.	Units
Mode compliance		PNP 24V			
Default state	Not supplied (+V _{LOG} floating or to GND)	High-Z (floating)			
	Normal operation	Logic "High"			
Output voltage	Logic "HIGH"; output current = 0.3A		V _{LOG} -1.0	V _{LOG} -2.0	V
	Logic "LOW"; output current = 0, no load	open-collector			
	Logic "HIGH", external load to GND		0		
	Absolute maximum, continuous	-0.3		V _{LOG} +0.3	
	Absolute maximum, surge (duration ≤ 1s) [†]	-0.5		V _{LOG} +0.5	
Output current	Logic "HIGH", source current, continuous			0.3	A
	Logic "HIGH", source current, pulse ≤ 5 s			0.4	A
	Logic "LOW", means High-Z			20	µA
Minimum pulse width		3	1.5		µs
ESD protection	Human body model	±15			kV

Mode compliance		NPN 24V			
Default state	Not supplied (+V _{LOG} floating or to GND)	High-Z (floating)			
	Normal operation	High-Z			
Output voltage	Logic "LOW"; output current = 0.4A		0.6	1.3	V
	Logic "HIGH"; output current = 0, no load	open-collector			
	Logic "HIGH", external load to +V _{LOG}		V _{LOG}		
	Absolute maximum, continuous	-0.3		V _{LOG} +0.3	
	Absolute maximum, surge (duration ≤ 1s) [†]	-0.5		V _{LOG} +0.5	
Output current	Logic "LOW", sink current, continuous			0.4	A
	Logic "LOW", sink current, pulse ≤ 5 s			0.5	A
	Logic "HIGH", means High-Z			20	µA
Minimum pulse width		5	1.8		µs
ESD protection	Human body model	±15			kV

OUT0 – Brake or general-purpose digital output² **Min.** **Typ.** **Max.** **Units**

Mode compliance		PNP 24V			
Default state	Not supplied (+V _{LOG} floating or to GND)	High-Z (floating)			
	Normal operation	Logic "High"			
Output voltage	Logic "HIGH"; output current = 1.5A		V _{LOG} -0.4	V _{LOG} -0.7	V
	Logic "LOW"; output current = 0, no load	open-collector			
	Logic "HIGH", external load to GND		0		
	Absolute maximum, continuous	-0.3		V _{LOG} +0.3	
	Absolute maximum, surge (duration ≤ 1s) [†]	-0.5		V _{LOG} +0.5	
Output current	Logic "HIGH", source current, continuous			1.5	A
	Logic "HIGH", source current, pulse ≤ 5 s			2.0	A
	Logic "LOW", means High-Z			50	µA
Minimum pulse width		30	15		µs
ESD protection	Human body model	±15			kV

Mode compliance		NPN 24V			
Default state	Not supplied (+V _{LOG} floating or to GND)	High-Z (floating)			
	Normal operation	High-Z			
Output voltage	Logic "LOW"; output current = 2.0A		0.2	0.3	V
	Logic "HIGH"; output current = 0, no load	open-collector			
	Logic "HIGH", external load to +V _{LOG}		V _{LOG}		
	Absolute maximum, continuous	-0.3		V _{LOG} +0.3	
	Absolute maximum, surge (duration ≤ 1s) [†]	-0.5		V _{LOG} +0.5	
Output current	Logic "LOW", sink current, continuous			2.0	A
	Logic "LOW", sink current, pulse ≤ 5 s			2.5	A
	Logic "HIGH", means High-Z			50	µA
Minimum pulse width		30	10		µs
ESD protection	Human body model	±15			kV

¹ For full RS-422 compliance, 120Ω termination resistors must be connected across the differential pairs, as close as possible to the drive input pins.

² The digital inputs and outputs are software selectable as PNP or NPN

Name ALN	First edition May 4, 2021	Document template: P099.TQT.564.0001	Last edition October 31, 2023	Visa: AS, AN
TECHNOSOFT		Title of document iPOS4815 MZ-CAT PRODUCT DATA SHEET	N° document P022.016.E122.DSH.011	
Page: 5 of 7				



iPOS4815 MZ-CAT DATASHEET

P/N: P022.016.E122

Encoder2 Inputs (A2+/Data+, A2-/Data-, B2+/Clk+, B2-/Clk-, Z2+, Z2-) ¹		Min.	Typ.	Max.	Units	
Differential mode compliance		TIA/EIA-422-A				
Input voltage	Hysteresis	±0.06	±0.1	±0.2	V	
	Differential mode	-14		+14		
	Common-mode range (A+ to GND, etc.)	-11		+14		
Input impedance, differential	A2+, B2+, Z2+ A2-, B2-, Z2-		150		Ω	
Input frequency	Differential mode	0		10	MHz	
Minimum pulse width	Differential mode	50			ns	
Sin-Cos Encoder Inputs (Sin+, Sin-, Cos+, Cos-)		Min.	Typ.	Max.	Units	
Input voltage, differential	Sin+ to Sin-, Cos+ to Cos-		1	1.25	V _{PP}	
Input voltage, any pin to GND	Operational range	-1	2.5	4	V	
	Absolute maximum values, continuous	-7		+7		
	Absolute maximum, surge (duration ≤ 1s) [†]	-11		+14		
Input impedance	Differential, Sin+ to Sin-, Cos+ to Cos- ²	4.2	4.7		kΩ	
	Common-mode, to GND		2.2		kΩ	
Resolution with interpolation	Software selectable, for one sine/cosine period	2		10	bits	
Frequency	Sin-Cos interpolation	0		450	kHz	
	Quadrature, no interpolation	0		10	MHz	
ESD protection	Human body model	±1			kV	
Analog 0...5V Inputs (REF, FDBK)		Min.	Typ.	Max.	Units	
Input voltage	Operational range	0		5	V	
	Absolute maximum values, continuous	-12		+18		
	Absolute maximum, surge (duration ≤ 1s) [†]			±36		
Input impedance	To GND		28		kΩ	
Resolution			12		bits	
Integral linearity			±2		bits	
Offset error			±2	±10	bits	
Gain error			±1%	±3%	% FS ³	
Bandwidth (-3db)	Software selectable	0		1	kHz	
ESD protection	Human body model	±5			kV	
LV-TTL UART (RS-232 with external transceiver)		Min.	Typ.	Max.	Units	
TTL TX	Voltage level	Absolute maximum, surge (duration ≤ 1s) [†]	-0.3		+3.6	V
		Logic 0		0	0.4	
	Logic 1	2.4	3.3			
Output current	Absolute maximum, surge (duration ≤ 1s) [†]	-5		+5	mA	
	-	-2		+2		
TTL RX	Voltage level	Absolute maximum, surge (duration ≤ 1s) [†]	-0.3		+3.6	V
		Logic 0		0	0.4	
		Logic 1	2.4	3.3		
	Input current		-0.15		+0.15	mA
Bit rate	Software selectable	9600		115200	Baud	
Short-circuit	TTL TX short to GND	-No-				
	Do not connect directly to standard RS-232 serial connector!					
	Always power-off the drive supplies before inserting/removing the adapter					

Safe torque OFF (STO1+, STO1-, STO2+, STO2+)		Min.	Typ.	Max.	Units	
Safety function	According to EN61800-5-2	STO (Safe Torque OFF)				
EN 61800-5-1/-2 and EN 61508-5-3/-4 Classification	Safety Integrity Level	safety integrity level 3 (SIL3)				
	PFHD (probability of dangerous failures per hour)	8*10 ⁻¹⁰			hour ⁻¹ (0.8 FIT)	
EN13849-1 Classification	Performance Level	Cat3/PLe				
	MTTFM (meantime to dangerous failure)	377			years	
Mode compliance		PNP				
Default state	Input floating (wiring disconnected)	Logic LOW				
Input voltage	Logic "LOW"	-20		5.6	V	
	Logic "HIGH"	18		36		
	Absolute maximum, continuous	-20		+40		
Input current	Logic "LOW"; pulled to GND	0			mA	
	Logic "HIGH"; pulled to +Vlog	5				
Repetitive test pulses	Ignored high-low-high				5	ms
	-				20	Hz
Fault reaction time	From internal fault detection to register DER bit 14 =1 and OUT2/Error high-to-low				30	ms
PWM operation delay	From external STO low-high transition to PWM operation enabled				30	ms
ESD protection	Human body model	±2			kV	

Ethernet Ports		Min.	Typ.	Max.	Units
Standard Compliance	EtherCAT (IEC61158-3/4/5/6-12)				
	Fast Ethernet 100BASE-TX (IEEE802.3u)				
	Auto-negotiation for 100Mbps/s full-duplex				
Auto-detect MDI/MDI-X					
Power over Ethernet	NOT used by the iPOS4815, requires separate +Vlog SELV/PELV supply	compliant to IEEE802.3af mode A "Mixed DC & Data"		NOT compliant to IEEE802.3af mode B "DC on Spares"	
Isolation GND0, GND1	Requirement for motherboard PCB routing	500			V _{rms}
Maximum cable length	2-pair UTP Cat5	100	150		m
ESD protection	Human body model	±4			kV

When the connections between drives is done directly, without magnetics (nonstandard, not conform to Ethernet IEEE802.3 100BASE-TX), it is imperative that the ground voltage difference between drives is kept to a minimum. The installation must provide a supplementary GND link between the drives. This link must have low inductance. Low inductance is best achieved by using large metal parts, such as a metallic chassis / baseplate, or using copper conductive tape.

LED signals		Min.	Typ.	Max.	Units
LED connection	Common cathode to GND				
LED current	Direct, no series resistor				
		0.7	1		mA
Conformity		Min.	Typ.	Max.	Units
EU Declaration	2014/30/EU (EMC), 2014/35/EU (LVD), 2011/65/EU (RoHS), 1907/2006/EC (REACH), 93/68/EEC (CE Marking Directive), EC 428/2009 (non dual-use item, output frequency limited to 590Hz)				

[†] Stresses beyond values listed under "absolute maximum ratings" may cause permanent damage to the device. Exposure to absolute-maximum-rated conditions for extended periods may affect device reliability.

¹ Feedback#2 differential input pins have internal 120Ω termination resistors connected across
² An 120Ω termination resistor should be connected across SIN+ to SIN-, and across COS+ to COS- signals.

³ "FS" stands for "Full Scale"

Name ALN	First edition May 4, 2021	Document template: P099.TQT.564.0001	Last edition October 31, 2023	Visa: AS, AN
		Title of document iPOS4815 MZ-CAT PRODUCT DATA SHEET	N° document P022.016.E122.DSH.011	
				Page: 6 of 7

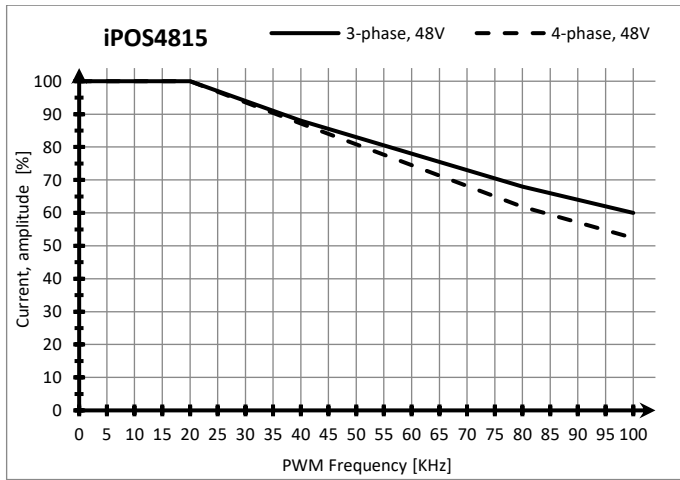

iPOS4815 MZ – Current de-rating with PWM frequency

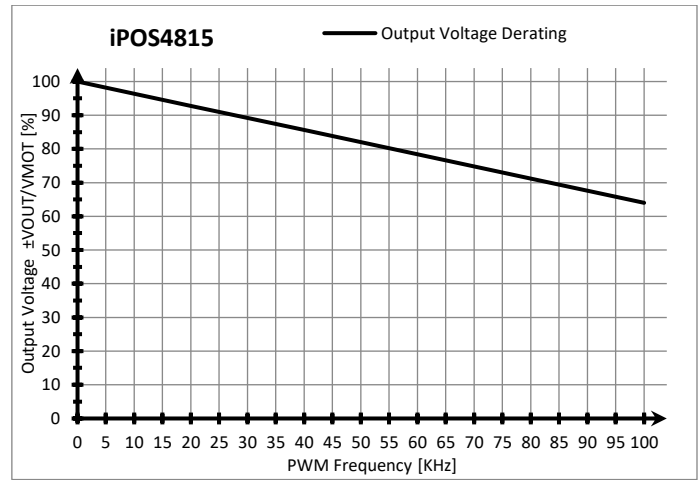

iPOS4815 MZ – Output Voltage de-rating with PWM frequency

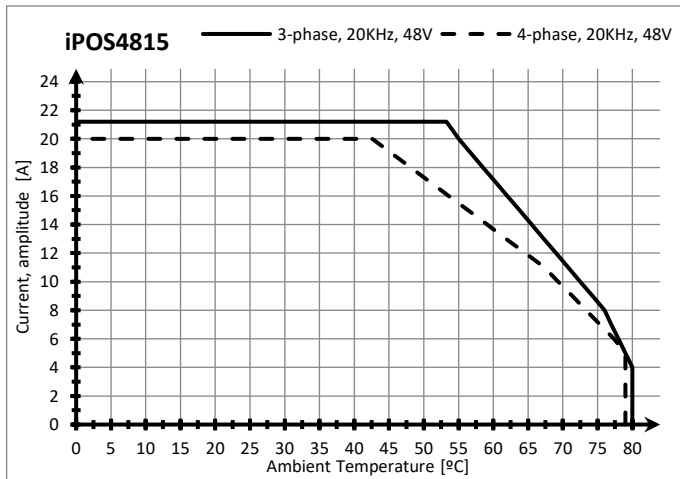

iPOS4815 MZ – Current de-rating with ambient temperature

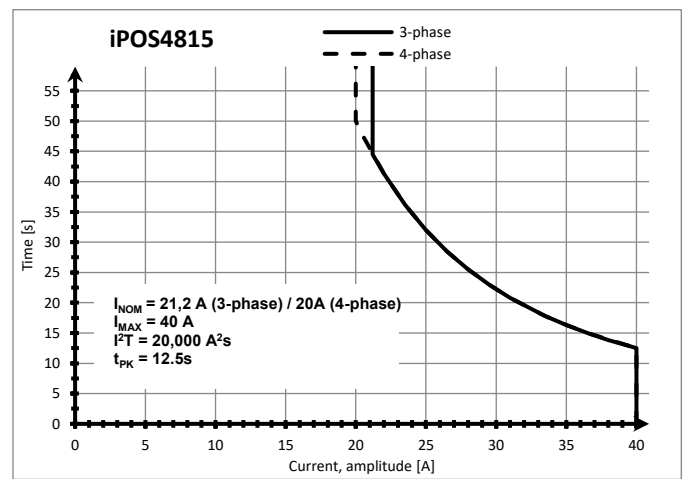

iPOS4815 MZ – Over-current diagram (No heatsink)

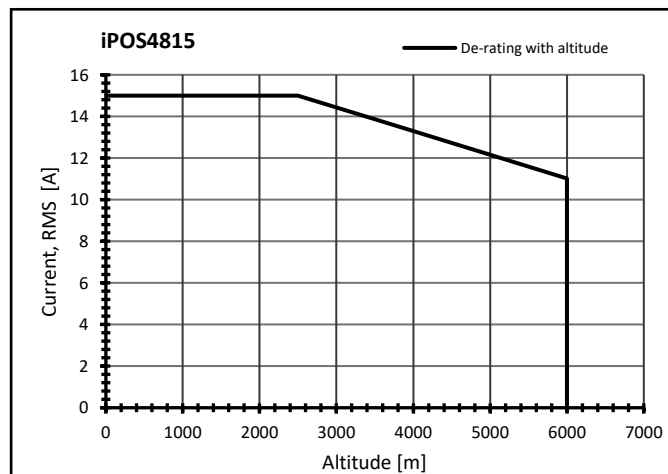

iPOS4815 MZ – De-rating with the altitude

Name ALN	First edition May 4, 2021	Document template: P099.TQT.564.0001	Last edition October 31, 2023	Visa: AS, AN
TECHNOSOFT		Title of document iPOS4815 MZ-CAT PRODUCT DATA SHEET	N° document P022.016.E122.DSH.011	
			Page: 7 of 7	