

All dimensions are in mm. Drawing not to scale. Pins facing upward view.

Motor – sensor configurations					
Sensor	Motor				
	PMSM	BLDC	DC BRUSH	STEP (2-ph)	STEP (3-ph)
Incr. Encoder	Ⓢ		Ⓢ	Ⓢ	
Incr. Encoder + Dig. Hall	Ⓢ	Ⓢ			
Linear Halls	Ⓢ				
Digital Hall control only	Ⓢ				
BISS / SSI / EnDAT / TAMAGAWA / Nikon / Sanyo Denki / Panasonic	Ⓢ	Ⓢ	Ⓢ	Ⓢ	
Tacho			Ⓢ		
Open-loop (no sensor)				Ⓢ	Ⓢ

Mating Connectors			
Producer	Part No.	Connector	Description
Samtec	SQW-117-01-F-D(-VS)	J1	2x17, 2.0mm THT (SMD) socket
	CLT-117-02-F-D		2x17, 2.0mm SMD pass-through socket
	SQW-110-01-F-D(-VS)	J2	2x10, 2.0mm THT (SMD) socket
	CLT-110-02-F-D		2x10, 2.0mm SMD pass-through socket
	SQW-103-01-F-D(-VS)	J3	2x3, 2.0mm THT (SMD) socket
	CLT-103-02-F-D		2x3, 2.0mm SMD pass-through socket

- **Features**
- Motion controller and drive in a single compact unit based on MotionChip™ technology
- Universal solution for control of rotary and linear brushless, brushed and 2 or 3-phase step motors
- Advanced motion control features, including CSP, CSV, CST, PVT, S-curve, electronic gearing, camming, and more.
- Motor supply: 48V nominal
- Motor output current:
 - Nominal: 5.7A_{RMS} / 8A amplitude for PMSM motors
7A for DC / BLDC / Step motors
 - Peak: 11.3A_{RMS} / 16A amplitude
- Logic supply: 24V nominal, 48V max
- Feedback Options:
 - 1 x Hall sensor interface (digital or linear)
 - Feedback#1 and Feedback#2 can be:
 - Incremental encoder A / B (index Z only for Feedback 1): differential or single-ended;
 - Absolute encoder: differential or single-ended. Supported protocols: SSI, BiSS, EnDAT, Tamagawa, Panasonic, Nikon, Sanyo Denki.
- 1 x analogue input, 12-bit, software selectable: 0-5V or ±10V; Reference, Feedback or General purpose
- 3 x digital inputs: 2 for limit switches + one Enable, NPN, pull-up on-board to +5V. Pull to GND to activate.
- 3 x configurable I/Os, each software selectable as:
 - Digital input, NPN, with pull-up on-board to +5V. Pull to GND to activate;
 - Digital output, NPN (open-collector), with pull-up on-board to +5V. Sink current: 1 x 1.5A to drive inductive loads (such as mechanical brake), 2 x 0.1A.
- Commissioning (set-up) possible through RS232, USB, FoE (file-over-EtherCAT) or EoE (Ethernet-over-EtherCAT)
- EtherCAT connection to standard RJ45: requires external magnetics (may be integrated into RJ45)
- 24Kwords E²ROM to store setup data, TML motion programs, cam tables and other user data
- 16Kwords SRAM memory for data acquisition
- Operating ambient temperature: 0-40°C (over 40°C with de-rating)
- Programmable protections: any short-circuit between motor phases, GND and/or supply, over/under-voltage, over-current, I²t drive & motor, control error
- 3 AxisID inputs, for hardware-based address setting
- >98% voltage efficiency, >98% power efficiency

Name ALN	First edition July 17, 2024	Document template: P099.TQT.564.0001	Last edition March 12, 2025	Visa:
		Title of document Micro 4804 PZ-CAT PRODUCT DATA SHEET	N° document P020.002.E322.DSH.10E	
				Page: 1 of 5



Micro 4804 PZ-CAT DATASHEET P/N: P020.002.E322

Pin	Name	Type	Description
1	+Vlog	I	Positive terminal of the logic supply input: 6 to 48 V _{DC}
2	A/A+	O	Phase A for 3-ph motors, A+ for 2-ph steppers, Motor+ for DC brush motors
3	GND	-	Ground return for logic supply
4	B/A-	O	Phase B for 3-ph motors, A- for 2-ph steppers, Motor- for DC brush motors
5	GND	-	Ground return for motor supply & shield for motor windings cable
6	C/B+	O	Phase C for 3-ph motors, B+ for 2-ph steppers
7	+Vmot	I	Positive terminal of the motor supply: 7 to 48 VDC
8	Cr/B-	O	Chopping resistor / Phase B- for 2-ph steppers
9	BFS	-	Boot Fail-Safe. Connect to GND to reprogram firmware in the improbable case when a power loss occurs during a firmware update and the normal firmware recovery fails
10	ID2	I	AxisID2 selection pin. See AxisID register settings table.
11	TX1-	I/O	Transmit/Receive negative, OUT port. Connect to magnetics PHY TX1 or directly to nearby RX0-
12	RX1-	I/O	Receive/Transmit negative, OUT port. Connect to magnetics PHY RX1 or directly to nearby TX0-
13	TX1+	I/O	Transmit/Receive positive, OUT port. Connect to magnetics PHY TX1 or directly to nearby RX0+
14	RX1+	I/O	Receive/Transmit positive, OUT port. Connect to magnetics PHY RX1 or directly to nearby TX0+
15	GND1*	-	Ground shield & center-tap for ECAT magnetics port 1
16	GND0*	-	Ground shield & center-tap for ECAT magnetics port 0
17	TX0-	I/O	Transmit/Receive negative, IN port. Connect to magnetics PHY TX0 or directly to nearby RX1-
18	RX0-	I/O	Receive/Transmit negative, IN port. Connect to magnetics PHY RX0 or directly to nearby TX1-
19	TX0+	I/O	Transmit/Receive positive, IN port. Connect to magnetics PHY TX0 or directly to nearby RX1+
20	RX0+	I/O	Receive/Transmit positive, IN port. Connect to magnetics PHY RX0 or directly to nearby TX1+
21	ID0	I	AxisID0 selection pin. See AxisID register settings table.
22	ID1	I	AxisID1 selection pin. See AxisID register settings table.
23	232TX	O	RS-232 Data Transmission.
24	232RX	I	RS-232 Data Reception.
25	...	Rsvd.	Reserved. Do not connect.
26			
27	IN2/LSP	I	5-48V digital NPN input. Positive limit switch input
28	IN3/LSN	I	5-48V digital NPN input. Negative limit switch input
29	IN5/Enable	I	5-48V digital NPN input. Drive Enable input
30	I/O0	I/O	5-48V 1.5A NPN (sink) general-purpose digital programmable input IN0 or output OUT0
31	I/O1	I/O	5-48V 0.1A NPN (sink) general-purpose digital programmable input IN1 or output OUT1
32	I/O4	I/O	5-48V 0.1A NPN (sink) general-purpose digital programmable input IN4 or output OUT4
33	GND	-	Ground return and shield
34	AnalogIn	I	Analog input (range software selectable 0-5V or ±10V)

* GND0, GND1, and all other GND pins are internally connected within the drive. However, it is strongly recommended to reserve GND0 and GND1 exclusively for EtherCAT-related functions, and avoid using them for any other purposes.

Pin	Name	Type	Description
1	ECAT ACT0	O	Shows the state of the physical link and activity for ECAT IN port. Active high, LV-TTL.
2	ECAT ACT1	O	Shows the state of the physical link and activity for ECAT OUT port. Active high, LV-TTL.
3	TML RDY	O	Lit after power-on when the drive initialization ends. Turned off when an error occurs. Active high, LV-TTL.
4	TML ERR	O	Turned on when the drive detects an error condition. Active high, LV-TTL.
5	ECAT RUN	O	EtherCAT® RUN indicator. Active high, LV-TTL.
6	ECAT ERR	O	EtherCAT® ERROR indicator. Active high, LV-TTL.

Pin	Name	Type	Description
1	+V USB	I	USB 5V detect input
2	GND	-	Ground return for USB
3	Hall1	I	Digital Hall, or Linear Hall sensor 1
4	Hall2	I	Digital Hall, or Linear Hall sensor 2
5	Hall3	I	Digital Hall, or Linear Hall sensor 3
6	GND	-	Ground return and shield
7	+5V	O	Supply for all feedback sensors
8	GND	-	Ground return and shield
9	EncA1+/EncA1/ Dt1+/Dt1	I	Encoder 1 A+/Data+ diff. input or single-ended input
10	EncA1-/Dt1-	I	Encoder 1 A-/Data- diff. input. Leave open for single-ended; Add externally 120Ω to pin 9 for differential
11	EncB1+/EncB1/ Clk1+/Clk1	I	Encoder 1 B+/Clock+ diff. input or single-ended input
12	EncB1-/Clk1-	I	Encoder 1 B-/Clock- diff. input. Leave open for single-ended; Add externally 120Ω to pin 11 for differential
13	EncA2+/EncA2/ Dt2+/Dt2	I	Encoder 2 A+/Data+ diff. input or single-ended input
14	EncA2-/Dt2-	I	Encoder 2 A-/Data- diff. input. Leave open for single-ended; Add externally 120Ω to pin 13 for differential
15	EncB2+/EncB2/ Clk2+/Clk2	I/O	Encoder 2 B+/Clock+ diff. input or single-ended input
16	EncB2-/Clk2-	I	Encoder 2 B-/Clock- diff. input. Leave open for single-ended; Add externally 120Ω to pin 15 for differential
17	Z1+	I	Encoder 1 Z+ diff. input or single-ended input
18	Z1-	I	Encoder 1 Z- diff. input. Leave open for single-ended; Add externally 120Ω to pin 17 for differential
19	USB DM	I/O	USB data-
20	USB DP	I/O	USB data+

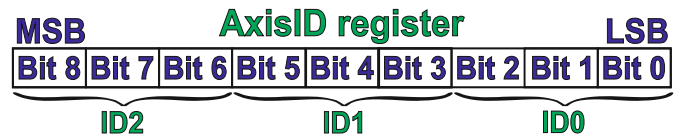

Nominal[V]	Minimum[V]	Maximum[V]	IDx* Bits	IDx* Value
0.000	0.00	0.53	000	0
1.06	0.53	1.41	001	1
1.76	1.41	2.01	010	2
2.25	2.01	2.43	011	3
2.60	2.43	2.75	100	4
2.89	2.75	3.01	101	5
3.13	3.01	3.22	110	6
3.32	3.22	3.30	111	7

Remarks:

1. $AxisID = (64 * ID2_Value) + (8 * ID1_Value) + ID0_Value$
2. If all "IDx" pins are left not connected or connected to GND, the AxisID value is 255 and the EtherCAT register called "configured station alias" will be 0.
3. Bit 8 (MSB of ID2) is ignored, and always considered as "0"

* where "x" can be 0, 1 or 2

Name ALN	First edition July 17, 2024	Document template: P099.TQT.564.0001	Last edition March 12, 2025	Visa:
		Title of document	N° document	Page: 2 of 5
		Micro 4804 PZ-CAT PRODUCT DATA SHEET		



Micro 4804 PZ-CAT DATASHEET P/N: P020.002.E322

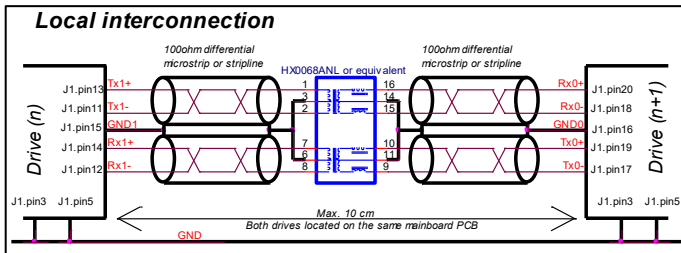
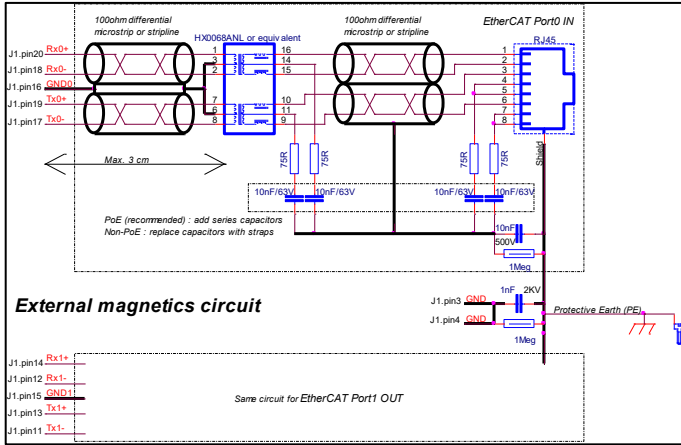

Electrical characteristics

All parameters measured under the following conditions (unless otherwise specified):

- $V_{LOG} = 24$ VDC; $V_{MOT} = 48$ VDC; $F_{PWM} = 20$ kHz
- Ambient temperature = 25°C (typical values) / 0°C...40°C (min/max values)
- Supplies start-up / shutdown sequence: -any-
- Load current = nominal

Operating Conditions		Min.	Typ.	Max.	Units
Ambient temperature		0		40 ^{1,2}	°C
Ambient humidity	Non-condensing	0		90	%Rh
Altitude / pressure ³	Altitude (vs. sea level)	-0.1	0 ± 2.5	3	Km
	Ambient Pressure	0 ²	0.75 ± 1	10.0	atm
Storage Conditions		Min.	Typ.	Max.	Units
Ambient temperature		-40		100	°C
Ambient humidity	Non-condensing	0		100	%Rh
Ambient Pressure		0		10.0	atm
ESD capability (Human body model)	Not powered; applies to any accessible part			±5	kV
	Original packaging			±15	kV
Environmental Characteristics		Min.	Typ.	Max.	Units
Size (Length x Width x Height)	Global size	38.3 x 26.8 x 11.3			mm
		~1.5 x 1.1 x 0.45			inch
Weight		22			g
Cleaning agents	Dry cleaning is recommended	Only Water- or Alcohol- based			
Protection degree	According to IEC60529	IP20			-
Power dissipation	Idle ($I_{MOT} = 0A$)		1	1.2	W
	Full power ($I_{MOT} = \text{nominal}$)		2.0	2.4	
Power efficiency	Full power ($I_{MOT} = \text{nominal}$)		98.7		%
	$f_{PWM} = 20KHz$		98.3		
Voltage efficiency	$f_{PWM} = 100KHz$		91.4		%
	Idle ($I_{MOT} = 0A$)		55		
Surface temperature ²	Full power ($I_{MOT} = \text{nominal}$)			100	°C

¹ Operating temperature at higher temperatures is possible with reduced current and power ratings
² In case of forced cooling (conduction or ventilation): a) the ambient temperature requirements may be extended substantially as long as the drive (PCB) temperature is kept below 85 °C; b) the spacing requirements can be dropped down to zero; c) the surface temperature will decrease accordingly

Mechanical Mounting		Min.	Typ.	Max.	Units
Airflow		natural convection ² , closed box			
Spacing required for horizontal mounting ²	Between adjacent drives		10		mm
	Between drives and nearby walls		10		mm
	Space needed for drive removal		20		mm
Insertion force	Between drives and roof-top		30		mm
Extraction force	Using recommended mating connectors			40	N
		8			N
Logic Supply Input (+V _{LOG})		Min	Typ.	Max.	Units
Supply voltage	Nominal values	6	24	48	V _{DC}
	Absolute maximum values, drive operating but outside guaranteed parameters	4.9		60	V _{DC}
	Absolute maximum values, continuous	-0.5		63	V _{DC}
Supply current	+V _{LOG} = 12V		90	150	mA
	+V _{LOG} = 24V		60	90	
	+V _{LOG} = 48V		45	60	
Utilization category	Acc. to 60947-4-1 ($I_{PEAK} \leq 1.05 \cdot I_{NOM}$)	DC-1			
Motor Supply Input (+V _{MOT})		Min	Typ.	Max.	Units
Supply voltage	Nominal values	7		48	V _{DC}
	Absolute maximum values, drive operating but outside guaranteed parameters	6		60	V _{DC}
	Absolute maximum values, continuous	-0.5		63	V _{DC}
Supply current	Idle		0.3		mA
	Operating		±7	±16	A
Voltage measurement error		±0.15		±0.25	V
Utilization category	Acc. to 60947-4-1 ($I_{PEAK} \leq 4.0 \cdot I_{NOM}$)	DC-3			
Supply Output (+5V)		Min.	Typ.	Max.	Units
Output voltage	Current sourced = 400mA	5.05	5.2	5.25	V
Output current	Output voltage ≥ 4.85V			1,200	mA
Short-circuit to GND protection		Yes / Drive resets at event			
Over-voltage protection		NOT protected			
ESD protection	Human body model	±1			KV
Motor Outputs (A/A-, B/A-, C/B+, CR/B-)		Min.	Typ.	Max.	Units
Nominal current ⁴	PMSM motors sinusoidal amplitude			±8	A
	PMSM motors sinusoidal RMS			5.7	A _{RMS}
	DC/BLDC/STEP motors continuous			7	A
Peak current	maximum 4 seconds	-16		+16	A
Short-circuit protection threshold			±25	±28	A
Short-circuit protection delay		2.6		3.5	µs
On-state voltage drop	Nominal output current; including typical mating connector contact resistance		50	70	mV
Off-state leakage current			0.3	1	mA
Current measurement	Accuracy (FS = Full Scale)		±1	±1.5	%FS
	Noise (current ≤ 2A)		±4	±6	mA
	Noise (current ≥ 2A)		±30	±50	mA
	Offset drift (compensated @ AxisOn)			±0.16	mA/°C
Motor inductance (phase-to-phase)	Recommended value to avoid spurious short-circuit protection, triggered by ripple	Fast loop ⁵ V _{MOT}			µH
		50µs 48V		133	
		100µs 48V		266	
		50µs 24V		66	
Motor electrical time-constant (L/R)	Recommended value for ±5% current measurement error	F _{PWM} = 20 kHz		330	µs
		F _{PWM} = 40 kHz		170	
		F _{PWM} = 60 kHz		140	
		F _{PWM} = 80 kHz		80	
				66	
Hall Inputs (Hall1, Hall2, Hall3)		Min.	Typ.	Max.	Units
Mode compliance	TTL / CMOS / Open-collector (NPN sink), or analog (linear) 0...5V				
Default state	Input floating (Wiring disconnected)	4.5	4.8	5.2	V
	Digital	Logic "LOW"		1.5	
Logic "HIGH"		3	2.5		
Hysteresis			0.5		
Input voltage	Analog	0	0.5...4.5	4.95	
Input current	Logic "LOW"; Pull to GND		2.4		mA
	Logic "HIGH"; Internal 2.2KΩ pull-up to +5		0		
Minimum pulse width			66		µs
ESD protection - Human body model			±15		kV

³ Micro 4804 can be operated in vacuum (no altitude restriction), but at altitudes over 2,500m, current and power rating are reduced due to thermal dissipation efficiency.

⁴ For current values >4A_{RMS}, pins J1/2...8 may need to be soldered instead of socketed, for long-term reliability - check socket manufacturer specifications.

⁵ Fast loop period of 50µs is not possible with all feedback device types.

Name ALN	First edition July 17, 2024	Document template: P099.TQT.564.0001	Last edition March 12, 2025	Visa:
		Title of document Micro 4804 PZ-CAT PRODUCT DATA SHEET	N° document P020.002.E322.DSH.10E	
			Page: 3 of 5	



Micro 4804 PZ-CAT DATASHEET

P/N: P020.002.E322

Digital Inputs (IN0, IN1, IN2/LSP, IN3/LSN, IN4, IN5/ENA)		Min.	Typ.	Max.	Units		
Mode compliance		NPN (sink)					
Default state		Logic HIGH					
Input voltage	Logic "LOW"	IN0, IN1, IN4, IN5/ENA	1.4	1.8	V		
	Logic "HIGH"		3.1	2.5			
	Hysteresis		0.9	1.1			
	Logic "LOW"	IN2/LSP, IN3/LSN	1.4	1.6			
	Logic "HIGH"		4	3.5			
	Hysteresis			0.6			
Floating voltage (not connected)		4.7					
Absolute maximum, continuous		IN2/LSP, IN3/LSN, IN5/ENA	-2	+80			
Logic "LOW"; Pulled to GND		IN0, IN1, IN4	-0.5	V _{LOG} +0.5			
Logic "HIGH"; Pulled to +24V			6.5	8			
Input current			0.2	0.4	mA		
Input frequency			0	500	kHz		
Minimum pulse			1		µs		
ESD protection - Human body model			±2		kV		
Digital Outputs (OUT0, OUT1, OUT4)		Min.	Typ.	Max.	Units		
Mode compliance		NPN (sink) 24V					
Load type		Resistive, Inductive					
Default state		Not supplied (+V _{LOG} floating)					
Immediately after power-up		High-Z (floating)					
		Logic "HIGH"					
Output voltage	Logic "LOW"; output current = 1.5A for OUT0/ 0.05A for OUT1, OUT4			0.4	V		
	Logic "HIGH"; output current = 0, no load	4	4.7	5.2			
	Logic "HIGH", external load to +V _{LOG}		V _{LOG}				
	Absolute maximum, continuous (free-wheeling diodes to +V _{LOG} to GND)	-0.5		V _{LOG} +0.5			
Absolute maximum, surge (duration ≤ 1s) †		-1		V _{LOG} +1			
Output current	Logic "LOW", sink current, short duration, duty cycle ≤ 1%	5s max	OUT1, OUT4	0.1	A		
			OUT0	2			
	Logic "HIGH", sink current, continuous; V _{OUT} ≤ 0.4V	0.5s max	OUT1, OUT4	0.15			
			OUT0	2.5			
	Logic "HIGH", source current; external load to GND; V _{OUT} ≥ 2.0V					5	mA
	Logic "HIGH", leakage current; external load to +V _{LOG} ; V _{OUT} = V _{LOG} max = 40V		V _{LOG} =24V	0.18		0.2	mA
		V _{LOG} =48V	0.42	0.45			
Minimum pulse width			0.5		µs		
ESD protection - Human body model			±25		kV		
Encoder Inputs (A1+, A1-, B1+, B1-, Z1+, Z1-, A2+, A2-, B2+, B2-)		Min.	Typ.	Max.	Units		
Single-ended mode compliance		Leave A1-, B1-, Z1-, A2-, B2- floating					
Single-ended threshold		TTL / CMOS / Open-collector (NPN sink)					
Single-ended input current		A1+, B1+, Z1+, A2+, B2+	1.3	1.4	1.5	V	
Differential mode compliance		For full RS422 compliance, see ¹					
Input voltage		TIA/EIA-422-A					
Hysteresis		±0.03	±0.05	±0.2	V		
Differential mode		-15		+15			
Common-mode range (A+ to GND, etc.)		-7		+12			
Input impedance, differential		Common-mode (A1+ to GND, etc.)		2.2	kΩ		
		Differential (A1+ to A1-, etc.)		4.4			
Input frequency		Differential mode		0	15	MHz	
Minimum pulse width		Differential mode		33		ns	
ESD protection		Human body model		±30		kV	
RS-232		Min.	Typ.	Max.	Units		
Compliance		TIA/EIA-232-C					
Bit rate		Software selectable		9600	115200	Baud	
Output voltage		±5	±5.7		V		
Short-circuit		232TX to GND					
Input voltage		Absolute maximum, continuous		-30	+30	V	
ESD protection		Human body model		±15		kV	

EtherCAT®		Min.	Typ.	Max.	Units	
Compliance		IEEE802.3, IEC61158				
Software protocols compatibility		CoE, FoE, EoE, IEC61800-7-301				
		Required, external				
Magnetics	Turns ratio	1:1				
	Inductance	350			µH	
	Common mode rejection	-30			dB	
	Center tap	to J1 pins 15, 16				
Transmission line	According to TIA/EIA-568-5-A	5	5e	6	Category	
	UTP	FTP	STP		Shield	
Auto	swap + / - inside a pair	Yes (MLT3 encoding)				
	swap Rx / Tx pairs	Yes (auto-MDI/MDIX)				
	Swap port0(IN) / port1(OUT)	NO (EtherCAT requirement)				
Configured Station Alias (using AxisID)		0 + 255				
ESD protection		Human body model		±5	kV	
Absolute encoder interface:						
SSI, BiSS-C, EnDAT, Tamagawa, Nikon, Sanyo Denki		Min	Typ.	Max	Units	
Single-ended mode		Not recommended, reduced robustness & speed				
Differential mode compliance		For full RS422 compliance, see ¹		TIA/EIA-422-A		
Output voltage	Differential; 50Ω differential load	1.5	3.3		V	
	Common-mode, referenced to GND	1	1.7	3		
CLOCK frequency	Nikon, Sanyo Denki	2.5, 4			MHz	
	Panasonic, Tamagawa	2.5				
	All others	1, 2, 3, 4				
Output Short-circuit protection	Common-mode voltage ±15V	Yes, protected				
DATA format	Software selectable	Binary / Gray				
		Single-turn / Multi-turn				
		Counting direction				
		CRC type				
DATA resolution	Including CRC, flags, ...		64	Bits		
If total resolution >31 bits, some bits must be ignored by software setting to achieve a max. 31 bits resolution						
Analog Input (REF / FDBK)		Min	Typ.	Max	Units	
Input voltage	Operational range	0...5, -10...+10				
	Absolute maximum values, continuous	-22		+26	V	
	Absolute maximum, surge (duration ≤ 1s)			±38		
Input impedance	To 1.44V		20		kΩ	
Bandwidth (-3dB)	Software selectable	0		5.3	kHz	
Resolution		12			bits	
Integral linearity				±1	bits	
Offset error	Range -10V ... +10V		±3	±10	bits	
	Range 0 ... +5V		±10	±30		
Gain error	Range -10V ... +10V		±0.3	±0.5	%	
	Range 0 ... +5V		±0.5	±0.8		
ESD protection		Human body model		±1.5	kV	
AxisID inputs		Min.	Typ.	Max.	Units	
Default state		ID1, ID1, ID2 floating				
Internal pull-down to GND		95	100	105	kΩ	
ESD protection		Human body model		±250	V	
LED outputs		Min.	Typ.	Max.	Units	
Polarity		Active high (high=LED lit)				
		Common cathode to GND				
Voltage	I _{OH} ≤ 0.9mA	2.9	3.3		V	
	I _{OH} ≤ 1.5mA	2.4			V	
	I _{OL} ≤ 2.0mA		0	0.4	V	
Current	Abs. max., continuous	-0.5		3.8	V	
		Sink (I _{OL}) current larger than source (I _{OH}) current		-2.0	+1.5	mA
Short-circuit protection		NOT protected				
ESD protection		Human body model		±250	V	
BFS input		Min.	Typ.	Max.	Units	
Polarity		Active Low (0=fail-safe boot, 1=normal)				
Default state		BFS floating		High		
Voltage	Logic low (active)		0	1.1	V	
	Logic high (inactive)	2.0	3.3		V	
	Abs. max., continuous	-0.5		3.8	V	
Current	Logic low (2.2KΩ pull to +3.3V)		1.5	1.6	mA	
	Logic high		0		mA	
ESD protection		Human body model		±250	V	

† Stresses beyond values listed under "absolute maximum ratings" may cause permanent damage to the device. Exposure to absolute-maximum-rated conditions for extended periods may affect device reliability.

¹ Full RS-422 compatibility, as well as noise rejection improvement requires an external 120Ω resistor connected across each signal pair (A1+/A1-, B1+/B1-, Z1+/Z1-, A2+/A2-, B2+/B2-)

Name	First edition	Document template: P099.TQT.564.0001	Last edition	Visa:
ALN	July 17, 2024		March 12, 2025	
		Title of document	N° document	
		Micro 4804 PZ-CAT PRODUCT DATA SHEET	P020.002.E322.DSH.10E	
				Page: 4 of 5



Micro 4804 PZ

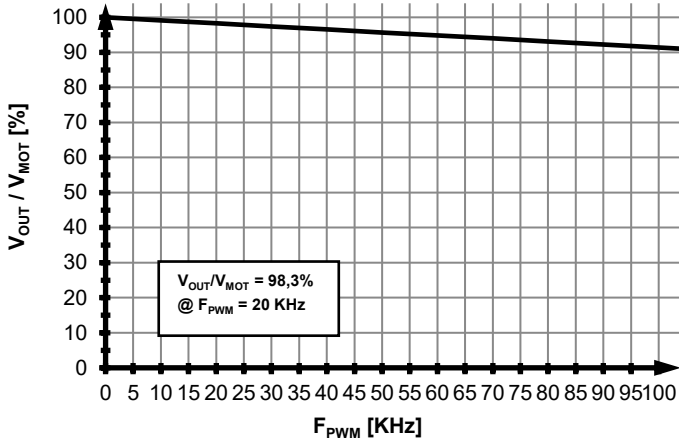

Micro 4804 PZ

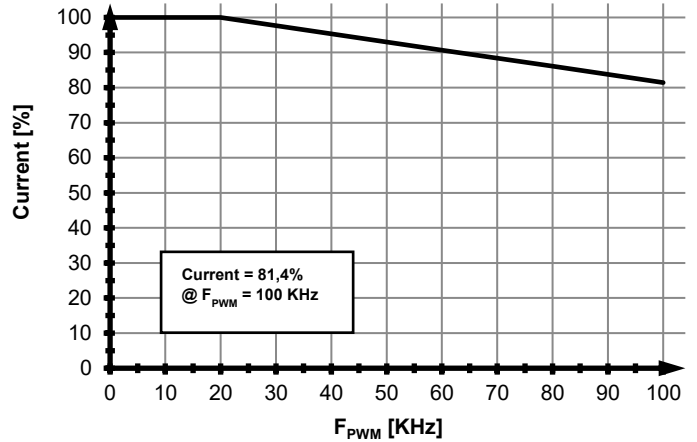

Micro 4804 PZ

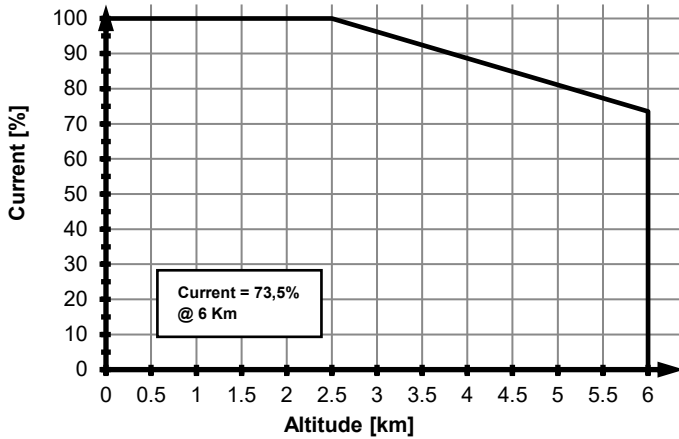

Micro 4804 PZ

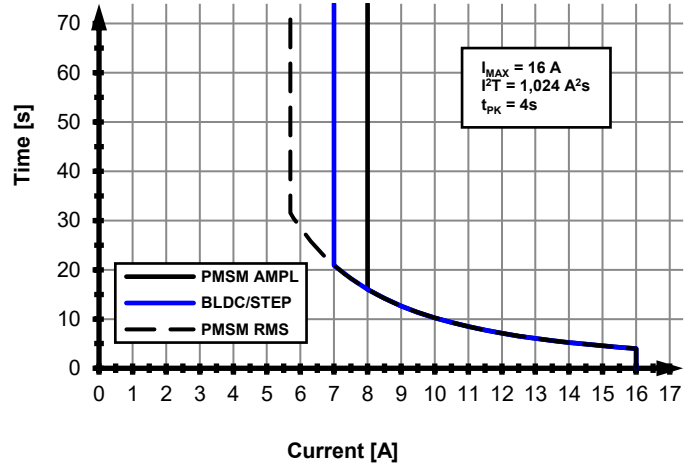

Micro 4804 PZ

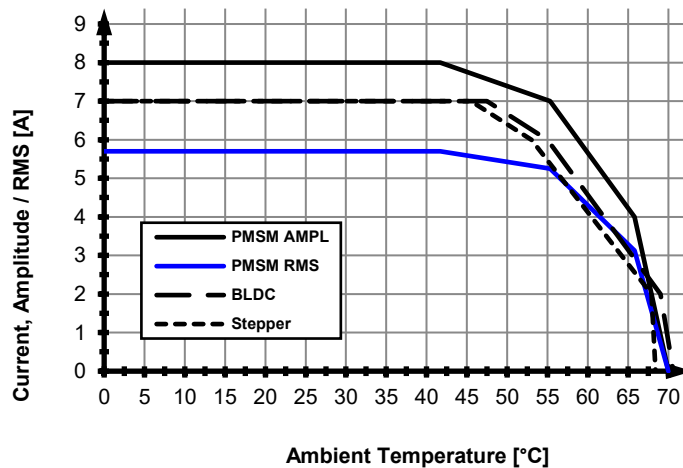

Name ALN	First edition July 17, 2024	Document template: P099.TQT.564.0001	Last edition March 12, 2025	Visa:
		Title of document Micro 4804 PZ-CAT PRODUCT DATA SHEET	N° document P020.002.E322.DSH.10E	
			Page: 5 of 5	